

Preparation of High Education in Applying International Audit Standard (ISA) in Audit Subject

Kazia LATURETTE

Universitas Ciputra, UC Town Citraland Surabaya 60219, Indonesia, E-mail: klaturette@ciputra.ac.id

Abstract Penelitian ini bertujuan untuk mengetahui pengaruh kesiapan tenaga pengajar dan dukungan institusi terhadap penerapan standar ISA di mata kuliah audit. Penelitian ini merupakan penelitian kuantitatif, dengan menggunakan alat uji PLS (Partial Least Square). Responden dari penelitian ini adalah Dosen Audit di Indonesia yang telah memiliki Sertifikasi Mengajar audit. Instrumen dari penelitian ini menggunakan kuisioner. Hasil dari penelitian ini menunjukkan bahwa Kesiapan Tenaga Pengajar berpengaruh signifikan terhadap penerapan International Standar Audit di mata kuliah audit, sedangkan Dukungan Institutional tidak berpengaruh terhadap penerapan ISA di mata kuliah audit. Hubungan Dukungan Institutional bersifat negatif terhadap penerapan ISA di mata kuliah audit. Keyword: Implemetation ISA, Readiness of Lecturer, Intitutional Support.

Key words ISA, High Education, Auditing

DOI: 10.6007/IJARAFMS/v7-i4/3437

URL: <http://dx.doi.org/10.6007/IJARAFMS/v7-i4/3437>

1. Introduction

Based on Law No. 5 of 2011 on Public Accountants, the Minister of Finance is authorized to grant permission to become a Public Accountant and to impose sanctions in the event that a Public Accountant does not comply with the provisions of the Act. The growth of the number of Public Accountants in Indonesia is increasing from year to year.



Source: The Center of the construction of the Financial Profession Secretariat General of the Ministry of Finance 2016

Figure 1. Graph of the development of the number of public accountant

Based on the graph above, in 2011 the number of public accountant as much as 712 declined in 2013 as much as 17 public accountant become 999 public accountant, but experiencing an increase in the year 2014. 54 public accountants become 1053 public accountant. The increasing number of Public Accountant in Indonesia is due to the fact that there are many opportunities for Public Accountant. The opportunities for the profession of an Public Accountant include: the only profession that is given the authority to provide audit services by the Ministry of Finance of The Republic of Indonesia, Laws PT requires the company with assets above 50 billion required in the audit, BPK will bestow state financial audit to the Public Accountant either directly or on behalf of the BPK, Open Companies based on the laws can only be audited by a Public Accountant, of State Owned Enterprises, Enterprises District and regional company this audit can be done

by a Public Accountant, audits and reporting in the tax sector, the tax sector already requires an audit for customer. (Sudarman, 2012) The existence of audit opportunities that so many, required also audit quality is good. A good audit quality is determined by the process INPUT, OUTPUT, important interaction in the chain of information provider financial reporting, and contextual factors. Inputs are grouped in the factors inputs are first, values ethics and the attitude of the auditor and second, knowledge, skills and experience and the experience of the auditor and the time available for the auditor perform this audit (Tuanakotta, 2015). It is important for the auditor to always hone themselves in order to have the quality of a good audit.

Indonesia adopted ISA (International Standard on Auditing) it is important that advanced PPAJP decision (now, the center of the construction of the Financial Profession shortened TOOLS)/Ministry of Finance in May 2012. ISA apply to the audit of the financial report issuer that started on or after 1 January 2013, and 1 January 2014 to an entity other than the Issuer (Tuanakotta, 2015). U.S. Audit Standards GAASH and ISA would have differences which is fundamental. According to Tuanakotta (2013) there are six things that differentiate between the two standards are risk-based audit, changes rule based standards become principles-based standards, turn away from the mathematical models, using professional wisdom, internal control and charged engines with governance.

PPAJP, IAPI Public Accountant Institute (Indonesia) individually or with other hood and some private universities disseminates their waste ISA in various cities in Indonesia in 2013, 2014, and 2015. The next step is to enter the ISA as part of the curriculum and syllabus of majoring in accounting in college. There are 43 state universities and the private sector in Indonesia that produce an accountant. Some of them will become a Public Accountant and Auditors, and compete with colleagues of students from ASEAN countries in the latter days. The adoption of the standard ISA in Auditing practices in Indonesia resulted in higher education should respond quickly changes lesson materials Auditing courses. Lecturers and students need a comprehensive knowledge about the basic ideas and ISA based audit process. So, it is expected that the lecturers and students can answer what, why and how the rules and standards applicable ISA (Tuanakotta, 2013 in Asmara *et al.*, 2016).

The question in this research is the first, whether the readiness of the teaching staff have a positive effect on the implementation of the ISA in audit courses and second, whether the support of educational institutions have a positive effect on the implementation of the ISA in audit courses. The purpose of this research is: first, to find out the influence of the readiness of the teaching staff of the implementation of ISA in audit courses. Second, to find out the influence of the education institution against the implementation of ISA in audit courses.

2. Literature review

2.1. International Standard Auditing

The international institutions that triggers and encourage the idea about ISA and IFRS is IFAC the International Federation of Accountants). Indonesia in IFAC membership represented by IAI (Ikatan Akuntan Indonesia). As a member of the IFAC in Indonesia has obligations stipulated in the Statement of Membership Obligation shortened SMO. This SMO consists of 7 liability that has been published on the month April 2004. One of the obligation is SMO 2 stating that deals with the education standards for professional accountant (International Education standard for professional accountants) and publications about education for professional accountant, and SMO1, 3 to 6 which is the "IAPI region) ata associated with the audit. In the adoption of this ISA Indonesia still do research how ISA 's implemented and attempt to translate into bahasa Indonesia. As many as 54 state from 126 IFAC member countries are still classified as category of others in the adoption of ISA in the country.

Hegarty, Gielen and Barros in the paper entitled "Implementation of International Accounting and Standard Auditing Lessons Learned from the World Bank's Accounting and Auditing ROCS program" in Tuanakota (2012) reveals the barriers in the implementation of the international standards in the experience of several countries namely: 1) misunderstandings regarding the nature of the international standards 2) No or lack of appropriate mechanism to provide the authority for the international standards at the national level 3). Not in line international standards with the legal framework in the country. 4) No or

lack the relevance of general purpose financial reporting and reporting that is determined by the regulator.
5) Is Not exactly the scope of the implementation of the international standards.

2.2. Readiness of Lecturer

Readiness According To Slameto (2010) principles of readiness include:

1. All aspects of the development of interact (mutual influence affect). In this research aspects of the development of interact is defined by the interaction between the teachers and the students who taught.

2. The physical and spiritual maturity is necessary to benefit from the experience. In this research the physical and spiritual maturity can be seen from the teacher education background and understanding of the teaching of Jesus that the higher is considered to have a high maturity level also.

3. These experiences have a positive impact on the readiness. In this research the experience seen with numerous seminars/workshop/training that followed by the teacher in knowledge and depth of ISA.

4. The readiness of the basis for the specific activities formed in a certain period during the period in the developmental period pembentuka. In this research the readiness of the basis for the activities can be seen with the readiness of the teacher prepare syllabus courses based audit ISA.

The availability of learning materials also affect the readiness of the individual to teach a matter, especially for new material. Langenderfer and Rockness (1989) in Widiastuti (2011) mentions that the barriers to practice for the implementation of the curriculum increased when not available adequate teaching materials related to a matter.

H₁ : Readiness of lecturer have a positive effect on the implementation of the ISA in audit courses

3.3. Institutional Support

Institutions describes the support the development of institutions in facilitating teaching staff in teaching ISA in audit courses. Institutional support merepresentasi support to the development of the individual in this facilitates the individual to increase the possibility of teaching materials in IFRS courses. According to a researcher, support can be given in the form of cooperation with other institutions that have knowledge of IFRS better as IAI and Public Accountant (HOOD), training, discussion forum internal study program and open to the public and submit to various pengajarnya staff training which diselenggarakan other institutions. Interwoven cooperation with other institutions especially appropriate in the context of the hood dissemination, training and the provision of teaching material related to IFRS. (Widiastuti, 2011).

H₂: Support Institutions have a positive effect on the implementation of the ISA in Audit courses

3. Methodology of research

This research is using primary data. The primary data obtained from the spread of the questioner to 30 lecturers in Indonesia that audit has get CTA (Certified Teaching in the Audit). The sampling techniques used are non-probability sampling with sampling forcible entry namely samples were selected based on the ease in obtaining the necessary data. Endogenous variable in this research is the readiness of the teaching staff and the support of the institution while the exogenous variable in this research is the implementation of ISA in audit courses. This research is a quantitative research using PLS model (Partial This Square). PLS consists of external relations (outer model or measurement model) and internal relations (inner model or structural model). Outer Model evaluation of the outer model done to judge the validity and reliability model. Outer models with reflexive indicator evaluated through convergent and discriminant validity of the former indicator latent change and composite reliability and Cronbach alpha to block the indicators. While the outer models with formative indicators are evaluated through the substantive content of him that is by comparing the greatness of relative weight and see the significance of the change indicator. (Chin, 1998 in Ghozali and Latan, 2012)

Inner model evaluation of the inner model aims to predict the relationship between the latent variable. Inner model evaluated by looking at the percentage of variance that is explained by the view the value of R-Square to change the latent endogenous. Geisser Stone-Geisser (1975) in Ghozali and Latan, 2012) test to test the predictive relevance, and average variance extracted (Ghozali and Latan, 2012) to predictiveness using resampling procedures such as jackknifing and bootstrapping to obtain the stability of the estimation (Ghozali and Latan, 2012). The analysis in this research is as follows: get the model based on

the concept and the theory for the design of the model of the structural design model measurement, create a diagram of the path, perform the conversion of the diagram path to equality, estimation, parameters to evaluate the model of PLS, to test the hypothesis and draw conclusions.

4. Discussions

Quantitative research data by demographics respondents namely gender, education deals, and old teaching from audit results of the questioner respondents. Questioner distributed to 30 Lecturers certified audit CTA in Indonesia. From the results of the questioner that were distributed to the respondents, obtained 53% of the total respondents is a type of gender women, while the rest as much as 47% of respondents is a type of gender man. The last education respondents, obtained 73% of the total respondents-educated Master, while the remaining 20% of respondents-educated Doctor , 4 % of respondents-educated Bachelor and 3% Diploma. One of the conditions to become a lecturer is a minimum-educated Master, so the majority of respondents-educated Master.

56% of the total respondents have long taught in the field of an audit of less than 5 years, 17% of respondents have experience teaching 5-10 years. While 13% of the total respondents have experience teaching for 15-20 years, 7% of the total respondents have experience teaching for 10-15 years and more than 20 years.

The following diagram of the path includes the value of loading factor of this research model:

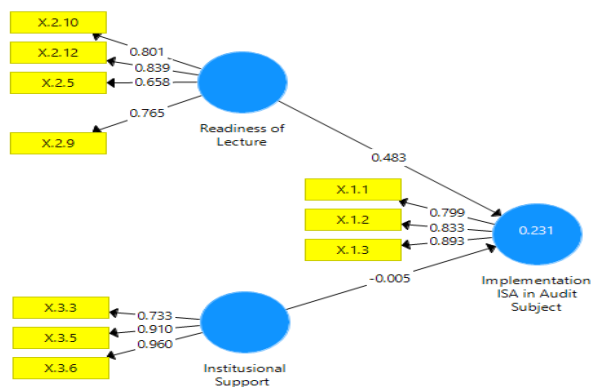

Figure 2. Path Diagram

Based on the graph 2. Explain that the latent variable readiness of lecture can explain the variants of X indicator X_{2.10}, X_{2.9}, X_{2.12}, and each of the more than 60%. The variants of X_{1.1}, X_{1.2}, X_{1.3} each can be explained by the latent variable implementation ISA in the audit subject more than 70%. Institutional support explain the variant of the variable X_{3.3}, X_{3.5}, X_{3.6} each above 70%.

Outter model

The next step is to evaluate the outter models with see the value of composite realibility, AVE, crobach alpha, and cross loading whether in accordance with the criteria specified, if appropriate means the model is valid and reliabel.

Table 1. Composite Reability, AVE, and Crobach Alpha

Variable	Composite Realibility	Composite Realibility Criteria	AVE	AVE Criteria	Crobanch Alpha	Kriteria Crobanch Alpha
Implementation ISA in audit subject	0.880	Reliable	0.710	Meet the criteria	0.796	Meet the criteria
Readiness of Lecture	0.851	Reliable	0.591	Meet the criteria	0.795	Meet the criteria
Institutional Support	0.905	Reliable	0.762	Meet the criteria	0.854	Meet the criteria

Source : though results PLS data

The value of composite reliability expected > 0.7, composite reliability values for the three variables > 0.7. This shows the three variables have reliability high data. The value of the AVE expected > 0.5, value AVE for the third variables >0.5. This shows the change correlates high. The value of Cronbach alpha for the third variable which is expected > 0.7, alpha Cronbach values for the three variables > 0.7. This shows the change have reliability good. To further evaluation discriminant validity are evaluated by using the value of the cross loading. The value of the cross loading from the three variables are as follows:

Table 2. Cross Loading

	Implementation of ISA in Audit Subject	Readiness of Lecturer	Institutional Support
X.1.1	0.799	0.404	0.163
X.1.2	0.833	0.334	0.194
X.1.3	0.893	0.459	0.256
X.2.10	0.182	0.801	0.345
X.2.12	0.550	0.839	0.377
X.2.5	0.242	0.658	0.497
X.2.9	0.274	0.765	0.423
X.3.3	0.081	0.208	0.733
X.3.5	0.221	0.472	0.910
X.3.6	0.268	0.551	0.960

Source : though results PLS data

From table 2 it is apparent that the latent variable correlation implementation ISA in subject audit with the indicators is higher compared with other latent variables with latent variable indicator variable. This applies also to all the latent variable lecturer readiness and raked support, with each of the indicators. It shows that the latent variables can predict the indicator on the block they better in appeal of other latent variable.

Evaluation of the structural model

Based on the results of the analysis obtained $R^2 = 0.361$, can be explained that the influence of the variables readiness of lecture (X1) and raked support (X2) against implementation ISA in subject audit gives a value of 0.361 is interpreted under the variables change implementation ISA in an audit of a subject can be explained by the variables change readiness of lecture and institutional support of 36.1%. While the remaining 63.9 % explained by other variables outside the examined.

The value of f^2 from readiness of lecturer variable is 0.481, this shows that the readiness of lecturer variable has a great influence on the structural level. The value of f^2 from institutional variable support has a value of 0.022, this shows that the variables institutional support has a small influence on the structural level.

Testing the hypothesis

before done done the process of bootstrapping hypothesis test on the sample data. The results of the bootstrapping Bootstrapping with samples assumed the data has been berdistribusi normal sehingga test parameters in the model can be done with test t.

The value of the coefficient structural model said significant if the value of t count > t the table of a 1.967 (1.967 is the value of the t tables in the level of confidence 95%). The results innermodel hypothesis test can be seen in table 3 with the results of the test all significant path.

Table 3. Path Coeffisien Diagram Test

Variable	Path Coeffisien	Error Value	T-Statistik	P Value	Information
Readiness of Lecturer	0.483	0.210	3.126	0.001	H ₁ Accepted
Institutional Support	-0.005	0.215	0.692	0.245	H ₂ Rejected

Sources :though results PLS data

The influence of the relationship between the latent variables exogenous to endogenous latent variable (Implementation of ISA in subject audit) in the table above can be explained as follows:

1. The path parameter coefficient obtained from the relationship between the variables readiness of lecturer with the implementation of ISA in the audit of 0.483 with T values of > 1.967 3.126 statistics on the rank of the significance = 0.05 (5%) stating that there is a significant impact between the readiness of lecturer with the implementation of ISA in subject audit. Positive values on the parameter coefficient means is the better readiness of lecturer and implementation of ISA in subject audit will increase Readiness lecturer.

This result is also supported by a statement from Ashraf etc (2015) states that Teachers are the most important element of any system of education. Management structure and environment is not the least factor that effect on teaching but qualification, training, motivation, experience, aptitude and so many other factors effect on it. Teachers have a great role on their students in enhancing the personal, social development and intellectual abilities. Teachers can have strong influence on their students that is deeper than others. In fact teacher said to be an ideal that the positive change in the overall attitude of his students by his performance and develop the good moral values.

2. The path parameter coefficient obtained from the relationship between the variables institutional support with the implementation of ISA in a subject of -0.005 audit with the value of T-statistics $0.692 < 1,967$ on equal significance = 0.05 (5%) stating that there is a significant impact between institutional support with the implementation of ISA in subject audit. Negative value on the parameter coefficient means is the better institutional support the implementation of ISA in subject audit will drop.

The results of this study are not in line with Sadaoughi's research, Hesampour (2016) which states that academic adjustment has a significant positive relationship with the dimension of social support. The results of this hypothesis are also given by respondents who fill the questionnaire, namely Lecturers who already have CTA. None or not supported by Lecturer's performance in teaching.

Based on the coefficient path parameter coefficient obtained in table 2 then the structural equation model that is formed is as follows:

The Implementation of ISA in subject = 0.483 audit Readiness of Lecturer - 0.005 Institutional Support

5. Conclusion

The conclusion from this research is:

1. Readiness of Lecturer has a positive significant effect against the implementation of ISA in subject audit.
2. Institutional Support does not a positive affect the significant impact on the implementation of ISA in subject audit

Acknowledgement

Researchers would like to thank the Ministry of RISTEKDIKTI over a grant which has been given so that researchers can perform this research with good.

References

1. Ashraf, I., Fawad, A., Irum Saeed, K., Nida, A., Waqasia, A. (2015). Teachers' Performance Problems in Higher Education Institutions of Pakistan. International Journal of Academic Research in Progressive Education and Development July 2015, Vol. 4, No. 3 ISSN: 2226-6348. www.hrmars.com
2. Baharuddin, Dkk. (2015). Teori Belajar dan Pembelajaran. Yogyakarta: Ar-Ruzz Media.
3. Corbin, J.M. and Strauss, A.L. (2015). *Basics of qualitative research: Techniques and procedures for developing grounded theory*.
4. Creswell, J.W. (2015). Penelitian Kualitatif & Desain Riset. Yogyakarta: Pustaka Pelajar.
5. Eka Noor, A., Supardi, D.S.A. (2016). Peran organisasional terhadap pengembangan bahan ajar pengauditan berbasis isa: perspektif dosen pengauditan. Soedirman Accounting Review 1(1) Desember: 1-20.

6. Hair Jr., et al. (2011). *Essential of Business Research Method*. USA: Sharpe. inc
7. Henseler, J., Ringle, C., Sinkovics, D. (2009). *The Use of Partial Least Squares Path Modeling in International Marketing*. *Advances in International Marketing*. No.20, pp.277-319
8. Pusat (2015). *Pembinaan Profesi Keuangan Kementerian Keuangan*. Republik Indonesia. Profil Akuntan Publik Kantor Akuntan Publik 2014. Jakarta. 2015 halaman 6. <http://pppk.kemenkeu.go.id/Publikasi/GetPdfFile?fileName=Profil%20AP%20dan%20KAP%202015.pdf>.
9. IAI. (2015, November 20). *Akuntan Tingkatkan Kemakmuran Ekonomi Bangsa*. Retrieved from <http://iaiglobal.or.id/v03/berita-kegiatan/detailarsip-865>.
10. Marshall, C. and Rossman, G. B. (2016). *Designing qualitative research*. Thousand Oaks, Ca. [u.a.: SAGE.
11. Marshall, Catherine and Rossman, B. Gretchen. (1989). *Designing qualitative research*. London, New Neldi: Sage Publications.
12. Mason, J. (2016). *Qualitative researching*. Place of publication not identified: Sage Publications.
13. Ramos, M.M. and Hidalgo, F.G. (2003). *From diagnostic to interactive style of management control*. *Management Research News*, 26(5), 21-31. doi:10.1108/01409170310783448.
14. Setyaningsih, I.D., Abrori. M. (2013). *Analisis Kualitas Lulusan Berdasarkan Tingkat Kepuasan pengguna Lulusan*. *Jurnal Ilmiah Teknik Industri*. Vol 12, No. 1 Juni 2013. ISSN 1412-6869: 73-82
15. Sedaoughi, H. (2016). *Relationship between Social Support and Loneliness and Academic Adjustment among University Students*. *International Journal of Academic Research in Psychology*, Vol. 3, No. 2. ISSN 2312-1882. www.hrmars.com.
16. Sholihin, M., Ratmono, D.D. (2013). *Analisis SEM-PLS dengan Wrap PLS 3.0 untuk Hubungan Nonlinier dalam Penelitian Sosial dan Bisnis*. Penerbit Andi Offset. Yogyakarta.
17. Simons, R. (2006). *Levers of control: How managers use innovative control systems to drive strategic renewal*. Boston, MA: Harvard Business School Press.
18. Slameto (2010). *Belajar dan Faktor-Faktor yang mempengaruhinya*. Jakarta: Rineka Cipta.
19. Sudarman (2012). *Peluang dan Tantangan Profesi Akuntan Publik di Indonesia dari masa ke masa*. 2012. *Dharma Ekonomi* No. 36/ Th. XIX/ Oktober, 1-9.
20. Tuanakotta. H. (2012). *Akuntansi Forensik dan Audit Investigatif (Standar Profesional Akuntan Publik)*. Jakarta: Salemba Empat.
21. Tuanakotta. H. (2012). *Berpikir Kristis dalam Auditing*. Jakarta: Salemba Empat.
22. Tuanakotta. H. (2013). *Audit Berbasis ISA (International Standard Auditing)*. Jakarta: Salemba Empat.
23. Tuanakotta. H. (2013). *Mendeteksi Kecurangan Laporan Keuangan*. Jakarta: Salemba Empat.
24. Tuanakotta. H. (2015). *Audit Kontemporer*. Jakarta: Salemba Empat.
25. Widiastuti (2011). *Kesiapan Dosen Akuntansi Dalam Mengintegrasikan Materi IFRS Dalam Mata Kuliah*. *Fokus Ekonomi (FE)*, Desember 2011, Hal. 204 – 216, Vol. 10, No. 3.