

Decision Support System for Assisting in Rail Traffic Management

Marcel Litra

CFR Passengers SA, Bucharest, Romania

Email: marcel.litra@cfrcalatori.ro

To Link this Article: <http://dx.doi.org/10.6007/IJAREMS/v3-i2/798> DOI:10.6007/IJAREMS/v3-i2/798

Published Online: 03 March, 2014

Abstract

For large companies and complex organizations, the information provided extensions transaction processing subsystems and the operative management information management system used by the systems to support tactical and strategic management subsystem, the data entry in tactical and strategic management subsystems. In a distinguished subsystems integrated both horizontally (usually the result of dividing the work areas) and vertically (resulting from the existence of different levels of decision). Traffic management is a specific activity that involves driving human operator decision support rail traffic. Current computer technologies allow processing of a segment of decisions, especially routine that allows automation of many phases of the decision-making information ¹. We propose establishing the methodological framework for the use of a decision support system to assist in operative management of Romanian railway traffic. We try to define three key concepts that appear in this issue: decision support systems (DSS), expert system (ES) and knowledge based expert system (KBES). Optimal solution will require more in-depth approaches depending on the specific problem.

Keywords: Decision Support System Support, Decision Support Systems, Expert Systems, Knowledge-Based Expert System, Rail Traffic Management

Introduction

If at first, expert systems have been developed in technical and medical lately witnessing an expansion of their economic, professional services, especially in the banking field. More and more companies are turning to companies producing artificial intelligence in order to create a knowledge base of their field of activity [Platon, S., Ionita, Pr. and Iovan, St. (2012)].

Efforts in this direction have resulted in many expert systems implemented in banks, insurance companies, in manufacturing, in services, large companies have allowed the implementation of emerging technologies.

¹ Iovan, Șt. (2013). O analiză de proces a managementului traficului feroviar românesc, București: Buletinul AGIR, Nr. 1/2013, pag. 63 - 67

Intelligent systems are used in legal aid agencies, financial accounting are the main market for expert systems manufactured by software companies to support those who practice liberal professions in which knowledge is essential capital and main service offered is a professional judgment.

Automatic exploitation of all situations generated by traditional financial accounting systems made possible by exporting them to a form intelligent little standard, paving the way for the implementation of systems analysis, diagnosis, control and forecasting business activity. This was the path to intelligent decision support.

Evolution ES systems to DSS

Processing of non-algorithmic (descriptive) knowledge into expert systems resulted in extending the application of information technologies. This expansion occurred horizontally into new areas of economic and social (educational, legal services, etc.) and vertically, to processing and process new information (such as evaluation of qualitative reasoning in a general sense). Consequently, current information technologies enable processing of a segment of social and economic decisions, especially routine that allows automation of many phases of the decision-making information.

Non-algorithmic information processing in expert systems can provide productive solutions to problems already addressed and resolved in a conventional manner (algorithmic). In areas where data and information requirements change frequently, algorithmic solutions difficulty adapts to these changes, sometimes at the cost of redesigning and laborious programming. Non-algorithmic technologies used in expert systems allow for a perfect adaptation to changes in the volume and structure of knowledge and information requirements.

Expert systems and adapt well to situations with incomplete and/or inaccurate. This is possible because expert systems allow the use in automatic reasoning heuristic rules validated by practice, which successfully completed formal approach.

Due to the form of expression of human experts "*usually true that*" or "*it can be said that*" difficulties in the decision-making occurs most often in obtaining information substantiating the decisions and not decisions. As a result, expert systems provide expansion particularly in data acquisition methods and methods of analysis. When we deal with the situation perfectly known (with full and accurate) is selecting the best possible decision options using expert system (especially if the number of feasible alternatives is very large).

In management, expert systems are used increasingly more. This is because any function management decision problems are complex, misunderstood, dynamic, multi-criteria decision which delayed development, while the pressure of decision making is high (risk of significant losses, sometimes dramatic).

Expert Systems

Artificial Intelligence and Expert Systems

Artificial intelligence dealing with intelligent behavior, and specifically to study the possibility of its emulation of the machine, namely calculating machines [Andone, I. (1994)]. Intelligent behavior means behavior that involves performing activities requiring special intellectual qualities such as: the possibility of abstraction, flexibility to adapt to new situations, creativity, etc.

Conventional data processing algorithm failed to transfer these activities to the intelligent machine (computer). Artificial intelligence is based on "*knowledge retention*" and

ensuring conditions for “*automatic processing of knowledge*”. Therefore artificial intelligence systems are called knowledge-based systems and knowledge base systems. We specialize in different activities [Andone, I. (1994), Airinei, D. (1995)].

Artificial intelligence systems have not only a knowledge base but also the mechanisms for their use (such as mechanisms resolution or inferential reasoning), the basis of facts and possibilities of description of activities that must execute (the tasks) with facts.

The process resembles the one we run it and we the people: first learn (or acquire knowledge) to be submitted in memory (equivalent knowledge base) but retain and facts (circumstances that occurred that knowledge involves each fact), and if we are to accomplish a task decomposition in steps (actions), and knowledge base extract knowledge associated with facts to be developed, that the knowledge that answers the question “*How should carry out the action (activity) X?*”.

In artificial intelligence, because the same knowledge can be used differently when solving different problems or to solve the same problems in different circumstances knowledge is made explicit and relatively independent of usage.

Making an artificial intelligence system has the task of identifying (represent) the knowledge necessary to carry out certain activities and to equip the system with mechanisms to allow application of this knowledge. This system must be able to make decisions at runtime about knowledge that are necessary for the task, how and when to use them for the task.

As a result, artificial intelligence methods and techniques must provide acquisition, representation and use of knowledge.

a) *Methods and techniques of acquiring knowledge* specify how to build the knowledge base in an artificial intelligence system. They are *theoretical learning* and *empirical learning* related empirical learning - *symbolic learning*.

At first we tried learning theory based on symbolic computation, but the results were not satisfactory. Following theoretical learning was supplemented by empirical learning applied to a knowledge base in the form of neural networks (*neural network based on knowledge*). Completion of this network with new knowledge (training) is based on training examples (applicable to this type of network) using one of the *algorithms for training neural networks*.

Training results in the form of *network parameter* values. In symbolic learning, these values are converted into knowledge represented symbolically by means of *algorithms for extracting knowledge from neural networks*, and added to the knowledge base. In addition to learning through training method, symbolic learning can be run and *inductive methods and techniques* (from examples, discovery, through observation) and *methods and techniques of learning by heart*.

b) *The methods and techniques of knowledge representation* define structures for knowledge representation and must satisfy the following requirements:

- Representational adequacy (to represent all categories of knowledge in a given domain);
- Adequacy purchase (to allow acquisition of knowledge);
- Informational adequacy (representation structures should allow the definition of operators (to be processed));
- Inferential efficacy (representative structures must allow processing only in terms of efficiency).

c) Methods and techniques for using the knowledge depend directly on the manner of representation. Basically, the use of knowledge is a process of applying a set of operators defined on structures of knowledge representation "*strong*" methods and "*low*" methods. As a result, each scheme has the corresponding representation in assembly methods and techniques of reasoning.

Methods and techniques of reasoning apply in a particular variant of reasoning in terms of completeness of knowledge and certainty, alternatively reasoning under incompleteness and uncertainty.

Expert systems - definition and architecture

Expert systems are artificial intelligence systems for solving difficult problems, the nature of practice in the performance of human experts. They realize automation expertise in a particular area called *area of expertise*.

a) Area of expertise is characterized by general knowledge, expertise and expert knowledge. In human cases, expert knowledge obtained by the expert - man through experience and outstanding individual qualities also distinguish it from other specialists in the field who have only general knowledge and specialist.

Knowledge associated with the domain expertise serve to solve problems in this area, which are generally homogeneous in type and can be considered as belonging to a certain class of problems. Description of a particular problem in this field is realized by presenting the status quo of the art of the field at a time.

b) The concepts associated with expertise in a related IT knowledge base and how it is built (acquired), how to solve reasoning, as explained user. Features and expertise define the architecture and concepts of it resulting components:

- *Knowledge base* (knowledge of the expertise represented in the form of structures such as formulas of predicate calculus, production rules, hierarchies frames, etc.);
- *Factual base* (contains a description of the problem to be solved. Structures are used for description of representation of fact, which is in the form of triples <object, attribute, value> or pairs <attribute, value>);
- *Mechanisms resolution* (ensure use of knowledge by implementing a set of operators defined on knowledge representation structures);
- *Workspace* (all intermediate results and operating parameters of the system settings);
- *Making interface* (all instruments with which it is possible to carry out the various components of the system);
- *User interface* (provides communication between system and user by the user to describe the problem and obtain the system of results and explanations on the results).

Knowledge Based Expert Systems

Knowledge-based expert systems are top achievements in artificial intelligence research in the form of software technologies. For software developers especially in disciplines such as medicine and engineering, are important because the decision process was

used symbols instead of [Andone, I. (1994)]. Tasks in the classification and diagnosis were the first to have benefited from the development KBES.

Many technical achievements were presented in conferences and books on the subject and appeared on the market in the late 70s and early 80s. A large number of articles have appeared in journals and magazines, especially about some expert systems: *DENDRAL* - for the analysis of molecular structures, *MYCIN* - expert system for the diagnosis and treatment of blood infections, *PROSPECTOR* for evaluating geological prospecting and drilling, or *TEIRESIAS* for intelligent acquisition of knowledge.

Definition 1. Expert systems are programs designed to address the problems of reasoning which usually requires considerable human expertise.

Definition 2. The expert system is a particular incorporating a knowledge base and an inference engine. The program acts as an intelligent advisor in a particular area.

These definitions provide an insight into the anatomy KBES and its operation. As a result of this development industry began to realize the potential of technology and has made efforts to bring laboratory prototypes to fully functional systems in this area.

What is an expert system based on knowledge?

Knowledge-based expert systems are computer programs created in order to solve a problem in a particular area [Airinei, D. (1995)]. The program uses knowledge of the field particular to a control strategy to achieve solution. An expert system is called the program, but a system as incorporating many different technologies such as knowledge base, inference mechanisms, explanation facilities, etc. All these different components interact to simulate the process of solving a problem by an accredited expert in the field.

A closer examination of any decision process made by an expert confirms that the facts and heuristics used to reach that decision. If the decision to be taken is based on a simple fact determined using heuristics, then it might be a trivial process. Note that the type of knowledge and other heuristic rules can be easily represented in the form of construction "IF - THEN", called production rules.

The two main components of an expert system can be identified as - or collective knowledge base of knowledge required solving the problem - control mechanism, which verifies the facts available, select the required source of knowledge of basic facts fit with the knowledge and generate additional facts. An expert system consists of five components:

1. *The knowledge base* serves to store all the elements of knowledge (facts, rules, methods of solving, heuristics) applied specific domain, taken from human experts or other sources.

2. *Inference engine* is a program containing control knowledge, procedural or operative, with which to exploit the knowledge base for making judgments as to obtain solutions, recommendations or conclusions.

3. *Dialog interface* allows dialogue with users during consultation sessions and user access to and knowledge of basic facts for adding or updating knowledge.

4. *Knowledge acquisition module* helps the user to introduce expert knowledge in a form recognized by the system and update the knowledge base.

5. *Explanatory module* aims to explain both the users' knowledge available to the system and the process of reasoning that we carry or the solutions obtained in consultation sessions.

The problem is more complex, the greater the number of facts that must be generated to solve it. In an application decisions are made sequentially using facts already established.

This process of using current facts and existing knowledge in the knowledge base to establish new facts or decisions that chain continues until a goal is specified as established fact.

Control mechanism handles symbolic processes called inferences. There are various methods by which knowledge contained in the inference rules can be used. It follows that the control mechanism may consist of a number of strategies inferences. Yet both, the knowledge base and control mechanism form the main components of an expert system based on knowledge.

Basic Concepts

KBES realized human knowledge processing. He can be found on any level management answers questions in a specific area by making inferences on the knowledge contained in the knowledge base, users are able to explain the reasoning and conclusions which led to a particular solution (decision).

Most experts present fundamental concepts KBES right *expertise*, *experts*, *expertise transfer*, *rules of inference* and the *ability to explain*.

Expertise is knowledge intensive, problem domain specific, acquired through training, reading, or experience long.

Human expertise covers a wide range of expert activities namely: recognition and problem formulation, accurate and fast problem solving, explaining the solution, learning from experience, knowledge restructuring, the fragmentation rules, determining the relevance, awareness of their limitations.

Transferring knowledge (rules and facts) are objective expertise KBES. Transfer occurs from the human expert computer users and hence human experts or non - experts. Based on expert knowledge base stored in the computer is authorized to reason exactly is programmed to do inference.

The rules of inference is rules are traditionally shaped IF-THEN-ELSE complementary in some applications the representation in frames.

KBES explanatory capacity is one of the factors that distinguish it from other types of systems.

KBES functions in decision making

From the point of view of management decision-making, expert systems have two important characteristics: *automating and improving decisions*, namely, *dissemination of expertise and normalization decisions*. Unlike DSS, which is designed to provide solutions or recommendations KBES maker aims to replace the capture and use knowledge from an expert and his expertise.

There tend expert systems integration and other areas of artificial intelligence in the decision support systems in order to obtain as Decision Support Systems for powerful and easy to use in terms of user interface.

Presentation KBES functions can only be arbitrary, given that meets KBES often complex tasks that cross borders defined. KBES functions can be classified as follows: *interpretation, diagnosis, training, monitoring, forecasting, simulation, planning, maintenance, design, control and operation*. Assist in decisions generally combined functions of planning, diagnostic and simulation.

Planning - is the definition of actions in time and space that allow to reach a final state by comparing the current state to the desired state, foreseeing the consequences of the action, in a manner which allows compliance with environmental restrictions, the available

resources and the foreseeable consequences of interactions between states and actions or between successive states.

Diagnosis - refers to the establishment of correlations between the characteristics or symptoms and situation type, and the simulation is the inference to be determined based on a model of the consequences of action or events triggered by the system found ongoing simulation.

The main reason for the replacement of human experts with expert systems is the economy of time. On the other hand, KBES "*is an excellent tool for protecting computer systems, because they process large volumes of data and performs reasoning*".

There are few cases in which expert systems completely replace human experts generally being used to improve the quality of decisions. Methods of problem solving or application of the rules differ depending on the persons who apply and interpret in their own way. A structuring of knowledge will lead to better management expertise.

Decision Support Systems

The increasing use of decision support systems is driven by the emergence of new information technologies and the volume required increasingly higher diversity and data to be processed to make an effective decision. They serve to improve the effectiveness of decision making (whether the decision is achieving its objectives) by providing decision - quality information and new ways of interpreting information Andone, I. (1994) ; Airinei, D. (1995)].

Definition. A decision support system (DSS) is an interactive system, flexible and adaptable designed specifically to provide support in solving unstructured or semi-structured decision problems, in order to improve decision making.

The database uses internal and/or external dates and models, provides a simple interface and easy to use, allows the decision maker to control the decision-making process and provides support for all stages of decision making, which are:

- phase identification and formulation of the problem;
- design stage (identification and evaluation of alternatives);
- choice phase of the solution;
- implementation phase of the decision;
- evaluation stage.

DSS's can provide advanced decision support multiple independent or interdependent, for a single user or group of users. If all phases of a problem are structured (procedures that are conducted standardized procedures are clear objectives for each and entrances and exits are clearly defined procedure), we deal with *structural problems*.

In a *structured decision* all or most of the variables are known and can be fully programmed. *Semi-structured decisions* can be programmed only partially and in addition requires human creativity and intuition. In *unstructured decision situations*, the targets are difficult to quantify and model the situation is almost impossible to plan.

DSSs provide support in solving the structural part of the decision. In the unstructured parts of the problem, they are to be solved without automation, direct decision maker, using his creativity. However there are a number of factors which make the use of solid state become ever more stringent.

For decisions to be processed a large amount of information, most often presented in different formats on different hardware platforms come and different data structures, which induce the need to use numerous applications for the extraction, preparation and aggregation data needed for the analysis and reporting.

User requirements change in a dynamic growing; resulting modification of data mining programs or creates new programs. To this is added another aspect, namely that decisions are not relevant to the transactions covered by the activity of a business or organization, but data about transactions that aggregated data. Data taken from heterogeneous sources are cleaned of unnecessary the decision, filtered and processed and then stored in a structure that is easily accessed and used by end users to query, reporting and analysis.

DSS needs to access and analyze data quickly and efficiently internal and external sources of the organization, generate alternatives (especially for structured problems) and decisions about alternative selection criteria will be proposed and can make predictions about the consequences of that alternative (to make analysis of "what-if" and "goal seeking" meaning "what would happen if ..." and "what goals I could achieve if ...").

DSS's are generally designed for specific situations and decision-making can not be generalized. It helps decision makers extend their ability to make decisions, but not replace them. Problems solved based models are part of the system. A DSS may be defined as a computer system consisting of three interacting components: a *data management component*, the component models and management component to ensure communication. In addition to these user interface.

a) Data management component. In business decision-making, based mostly on knowledge, information is processed data are evaluated in relation to existing knowledge and stimulate the creation of new knowledge. We can say that we have one relation *Dates - Knowledge - Information*.

Some systems of decision-making can be based on the relationship *Knowledge - Information - Dates*. This implies that there is knowledge to seek information and then data. Other systems of decision-making can be based on the relationship *Information - Data - Knowledge*.

In the last phase of decision making, information is processed and establishes the decision may take the form of data and its expression leads to new knowledge will be added to the existing ones. In the three types of relationships above:

- *data* can be in the form of : empirical data, unprocessed (raw) data available from previous experiences, data from the current decision-making process;
- *information* can be : internal, available in early decision process, obtained from data processing or other information external to the organization;
- *knowledge* can be : learned and apply early decision process, obtained by transforming raw data into information or data extraction to end of information acquired during the decision making process.

Data from the DSS database may come from internal sources, external and private. Internal data refers to the organization's resources (human, technical, financial) processes, events and activities in the organization.

Data from external sources relate to the environment (economic, natural, social) in which the organization operates and may come from mass media, opinions of customers and partners, market research firms and forecasting, Internet, and so on Data from private sources (belonging to employees of the company) internal rules used by decision makers to evaluate the data or activities.

b) Management component models running loading, storing and organizing various quantitative models providing analytical decision support system facilities. It consists of the base models, the management of the base models, catalog models, processor performance, integration and ordering pattern.

- *Database models* include different statistical models of financial mathematics and other quantitative models used to execute various tests. DSS should be able to run, modify and control models. After the decision to which they are used, the models are classified into patterns *strategic, tactical* and *operational*.
 - *Strategic models* are generally very complex, with many variables; with a broad horizon of time (usually years) tend to be descriptive rather than optimization, use more external than internal database data.
 - *Tactical models* are used in work allocation and control of resources, each model is dedicated to a task, the time horizon extends from one month to two years, using many internal data and external data than can be both optimized models as and descriptive models.
 - *Operational models* are used in daily activities (quality of service, traffic planning), the time horizon is small (day) and use many internal data.
 - *Database management system* is used to manage models based on models and has the following functions:
 - possess appropriate modeling language for creating decision models according to user requirements;
 - allows the integration patterns by controlling the order of execution models;
 - allows the user to manipulate scenarios and models to perform complex analysis;
 - provides a catalog of patterns stored, with a description of their functions and applications that are used.
 - *Catalogue of models* contains definitions of models, job descriptions and applications that are used. Since the selection of a model involving experience from the system to a DSS this should be done by the user.
- c) To ensure communication component** aims DSS architecture, security issues and network. DSS architecture can be represented on four levels:
- Process flow diagram showing the process of review activities;
 - System architecture as it relates to software components;
 - The technical architecture that relates to the hardware, and the kind of network protocols;
 - Delivery architecture DSS that focuses on system outputs.

A well-defined architecture helps decision makers to work together and increase the team's ability to communicate with managers. Computer networks are a critical element of the IT infrastructure. Regarding the security plan, system administrators and managers must take into account the following factors: the importance of the system, its validity and stored data, the volume of effort required ensuring system security and how security plan set affects users of the system.

d) The user interface contains the following components:

- *communication language* allows interaction DSS and supports communication between the system users;
- *presentation language* allows the presentation of data in a variety of formats; serves to transmit information and commands to the DSS.

At the interface design should we consider factors associated with human interaction such as accessibility, ease of use, level of skill, capturing and reporting errors.

e) User. Design, implementation and use of DSS can be complete only if the user has the role, which is manifested by his skill, his motivation, his field of knowledge, patterns of

use and its role in the organization. User is defined as the person or persons responsible for providing a solution to the issue under examination or to take a decision in the context in which it was built DSS.

Railway Management Processes

Time evolution and technological developments have highlighted the need for process management systems to support rail. Figure 1 illustrates the principle of a process management. According to systems theory, the process is treated as a functional block based on a set of their own rules, processes a set of inputs to generate the set of outputs required. Working within the process is subject to external or internal disturbances that lead to alteration of results (output) process.

The effectiveness of a process management is the ability to adapt the internal processing so as to mitigate variation and disturbance input quantities in order to obtain values in the range output quantities accepted [Iovan, Șt. (2013); Iovan, Șt. & Litra, M. (2012)]. To achieve this goal it is necessary to continually adjusting the operation of the process in relation to changes in inputs and disturbances.

Systems theory has imposed the notion of "control loop" (feedback) that continuously checks the values of output in relation to objectives and, through the process set their own rules, decide on issuing orders for correction of how such processing that the values of the output to be as close to the targets. Process control (management) is permanent, which is likely to secure a system as consistent as possible targets.

For complex a system, system operation aims to turn suffer a permanent adjustment in relation to the environment (disturbances) and the variation of the input quantities. Generally adaptation subject of planning objectives. Planning is a component of complex management activities in consecutive control loops, which performs successive adaptation of objectives to operational command level adjustment process.

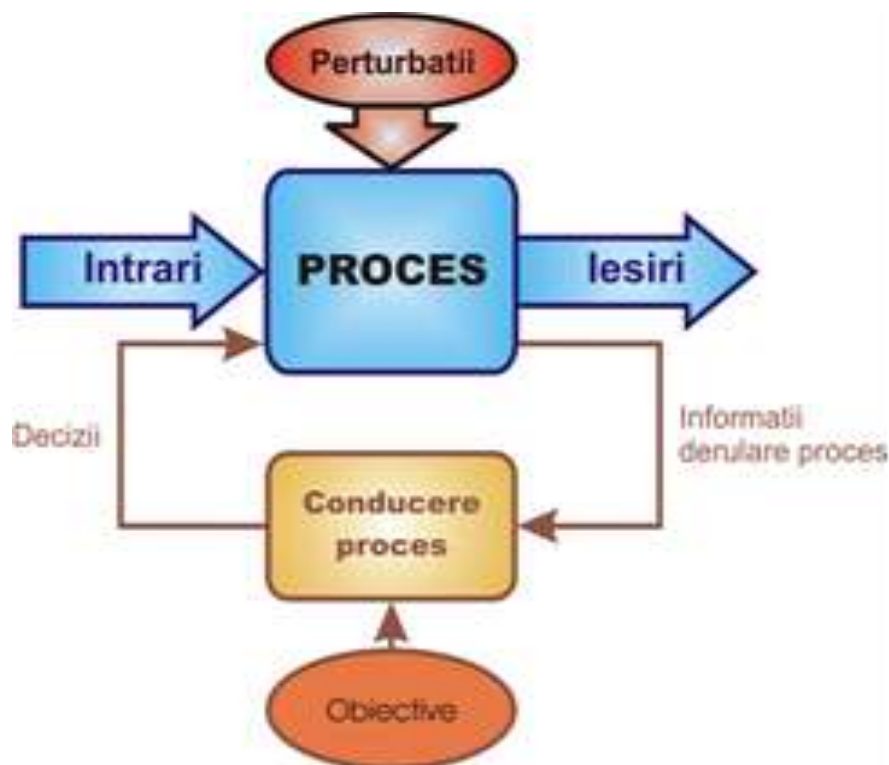

Figure 1. Principle management process

The railway traffic management has been highlighted three consecutive control loops defined on the time horizon for the analysis of system behavior and its management decision making.

The first control loop is operative control loop which adjusts the current operation of the process for granting its operational objectives developed by senior management level. The operational management is carried out in near real-time, during the course of the process, the time horizon of decisions generated is very short, and the role of these decisions is that of adapting the current (instantaneous) process operation.

The operational objectives are generated by tactical management level, acting on a medium time horizon. This involves assessing the behavior of the process last time and compared with the targets a tactical decision on the operation process is developed in the next period. Decisions at this level are materialized in the form submitted to the operative management objectives [Iovan, St. & Litra, M. (2012); Iovan, St. & Daian, Gh.I. (2012)].

The highest level of management is the strategic process that regulates the operation of a general time horizon, based on strategic objectives and statistical evaluation of the functioning of the process in the past. Decisions of the management level materialize as tactical objectives imposed leadership.

In terms of time, so the strategic as well as tactical leadership are activities that are carried out prior to trial. Tactical and strategic leadership that is based on the results of the analysis of the work carried out, analyzing the post-trial activity.

The following figure (Figure 2.) is the schematic principle of distribution in time steps of a process management. The figure illustrates the situation leadership process train movements. The operational management is carried out during the actual conduct of the process that led to the example considered, while the train is in movement (the period between the dispatch and arrival). The operational management of train movements shall be based on a plan (program service), which is drawn prior to dispatch of the train. Program management stage movement is the result of train traffic tactic.

Overall management strategy (programming movement) covers a time horizon of up to 30 days prior to dispatch of the train. In turn, the timetable is achieved by adapting a framework circulation plan prepared for a long time. Romanian Railways timetable drawn up for a period of 12 months on freight trains for a period of 6 months to passenger trains. Railway is the main result of strategic management phase of train movements. Subsequently termination process (train arrives at destination) is conducted retrospective analysis of the process. Post-process analysis activities are designed initialization of new cycles of activity at different stages of the management process.

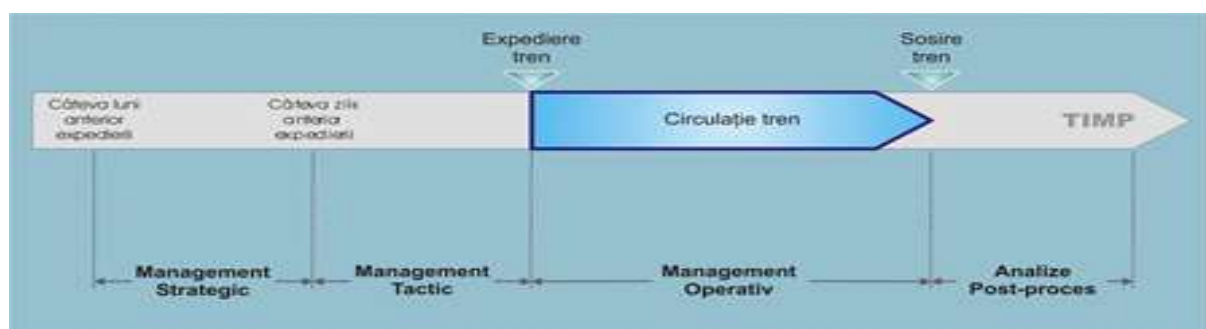

Figure 2. Distribution in time steps of a process management

The steps of the process management are consecutive in the time and activities are functionally linked, in the sense that the results of steps are inputs for the next stage. There are also iterative activities, as each step is taken cyclically based on information on the results of the previous cycle (information developed in the course of post-trial analysis) [Iovan, St. & Daian, Gh.I. (2012)].

Rail Traffic Management illustrates the general case of driving a process of service delivery. Entries are relevant to the activity service requests and available resources for implementation services. Work sequentially through the following steps:

- *Strategic management*, strategic plan execution completed by services;
- *Tactical management*, completed the program (tactically) achievement of service;
- *Operative management*, the result of which is to deliver scheduled services;
- *Post-process analysis*, the results of which serve to initiate new cycles driving the process.

This chapter has been submitted action disturbing factors influence the process.

Train Traffic Management

When running trains general organizational management process should be reconsidered in the light of particular aspects related to traffic safety. When driving there is another train traffic control loop in addition to the general organization shown in the previous paragraph. It is the control of the safety loop. This control loop is closest to the process, meaning that any decision to conduct traffic (basically it's about operational management decisions) shall apply exclusively through the filter process introduced safety rules that must satisfy process.

In practice, this control loop is embodied in the current through the stations and lines:

- Application assembly safety rules on the movement and maneuver stations and current lines.
- Railway signaling systems, which ensure the implementation of some of the safety rules and enforcement actions independent of human operators.

The scope of the functional activities not directly covers the problems relating to the safety of the control loop. However, business analysis on traffic management must take into account all relevant aspects of traffic safety control loop. The need for such an approach is required for a number of reasons, among which are the following:

- Any decision on traffic management must take into account the impact of the safety rules and how to implement them.
- Application traffic management decisions are made via railway signaling installations, which should be considered together with rules that govern their use.
- Railway signaling and electrical and/or electronic implements control functions of the position and movement of trains. These plants are holders of primary information on monitoring the movement of trains, valuable information due accuracy and efficiency.

In light of these considerations, the rail traffic management operational structure consists of four consecutive control loops defined mainly based on the time horizon for the analysis of behavior and decision-making process leading to it [Iovan, St. & Litra, M. (2012), Iovan, St. & Litra, M. (2013)].

The highest level of management is the strategic process that regulates the operation of a general time horizon, based on strategic objectives and statistical evaluation of the functioning of the process in the past. The annual plan is tailored and refined periodically report progress and concrete applications transport conditions due process. The main result of tactical management is the timetable of trains. The operative continuously adjusts its operation process for granting operational objectives developed at the tactical leadership.

Applying operational decisions filtered through assembly safety rules on the movement and maneuver stations on current lines. This is done in the activities that were mentioned by the name of "*security control*". This is the loop closest to the process control, including the task of having to generate decisions to make the process safe state when any dangerous situation is identified. Such decisions take priority over any other operational decisions.

Note that in Figure 3, the influence of disturbances undergone by the unusual was depicted in in order to highlight the influence of disturbances on the process of decision. Analyzing loops in order of proximity to the reaction led, decisions will have to mitigate the consequences of the following types of disturbances:

- *Adjusting security* must take into account the disturbing events of which may influence safety.
- *Operative management* is faced with mitigating the consequences of any type of disturbance that can affect the circulation.
- *Tactical management* must take into account foreseeable limitation of infrastructure availability or limiting the availability of railway signaling systems.
- Strategic management due to its planning framework can not be influenced by the potential occurrence of events of disruptive.

Levels of Command and Control

In the Romanian railway system, traffic management activity is implemented by a pyramidal organizational structure [Iovan, Șt. (2013)], in which there are four levels of decision hierarchy (Figure 4.):

- *Central level* (Level 1), represented by the central dispatcher driving the movement, called the Central Railway Traffic Management (BCCTF).
- *Regional level* (Level 2) consists of leading regional dispatch movement called Regional Traffic Controllers (RCR). Railway network is divided into 8 regions, which correspond to eight administrative entity type branches. Traffic management activity across such a region is coordinated by RCR, who reports functionally to the central level.

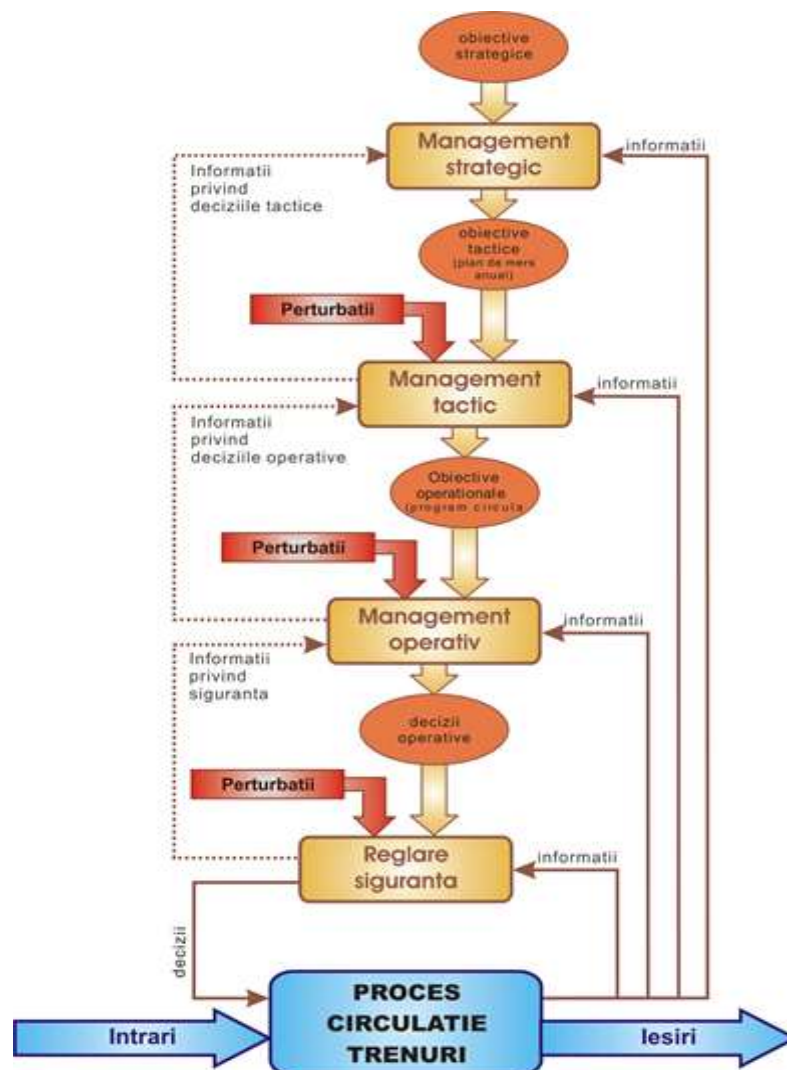

Figure 3. Train traffic management organization

- *Zonal level* (Level 3), represented by the dispatch area driving traffic controllers called Circulation (RC). Each region is divided, in terms of driving traffic into 2-4 distinct areas coordinated by a RC. In the network there are 23 CFR traffic controllers. Activity across regional regulators is coordinated by RCR.
- *Station level* (Level 4). The railway network is 994 railway stations. In terms of traffic management, each station is uniquely subject of traffic rules.

The diagram in Figure 4 has been revealed yet another level of decision which we consider particularly relevant in terms of operational management traffic. The railway network of each traffic rules (RC) is divided into zones led by a human operator. One such area is called driving traffic RC thread. Since the RC wires are part of RC, we conclude that it is a sub- level of level 3 decision, therefore indicated in Figure 4 under the name Level 3.

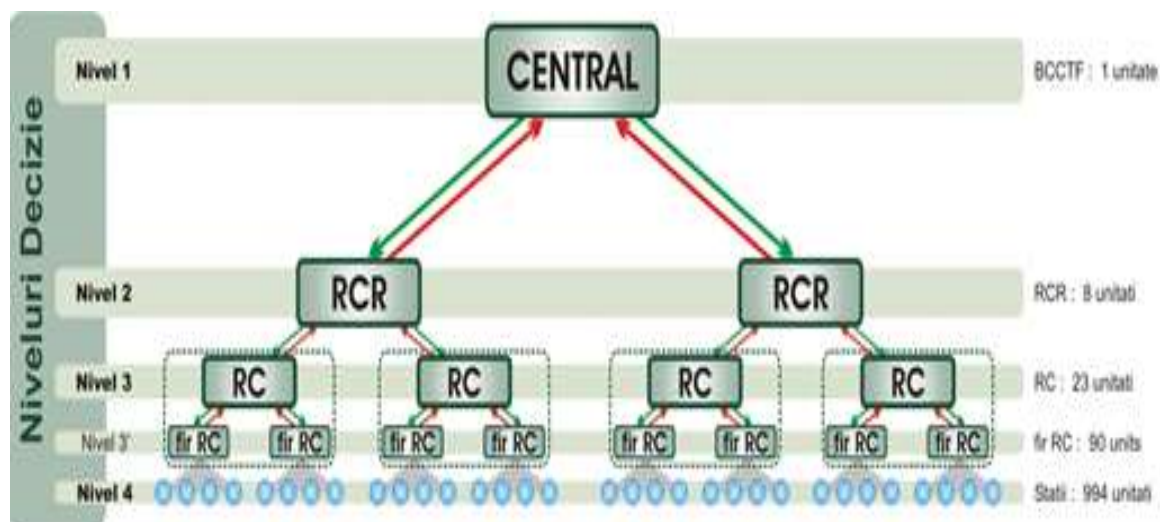

Figure 4. Levels of decision in railway traffic management

Preliminary analysis reveals that there is a separation of powers within the wires between the RC and RC, in that:

- the RC wires is developed traffic management decisions for the run;
- the RC shall ensure coordination of activities and develop decision RC wires on flow conditions at the borders between adjacent RC wires.

The organizational structure described above implements all traffic management activities. There are some differences caused by the specifics of each type of activity.

Conclusions

From the perspective of the situation highlighted in this analysis, the objective of this work is to exploit one of the courses of action needed to halt the decline of the railway system [Iovan, St. and Litra, M. (2013)]. This course of action aimed at the massive use of computer technology as a support for the following objectives:

- Improved performance of rail services with a focus on transport speed (average speed commercial) and on punctuality;
- Limiting operating costs by increasing the efficiency of the fields of Traffic Management.

This paper is focused on business process remodeling massive use of computer technology [Litra, M. & Iovan, St. (2012), Litra, M., Szentes, Is. & Iovan, St. (2013)]. In particular, the paper focuses on the problem of increasing the efficiency and performance in the field of traffic management.

References

- Iovan, Șt. (2013). *O analiză de proces a managementului traficului feroviar românesc*, București: Buletinul AGIR, Nr. 1/2013, pag. 63 - 67;
- Platon, S., Ionita, Pr. and Iovan, St. (2012) *Relaunching Intermodal Freight Transport – A New Approach*, Constanta: Railway PRO Science & Technology Official magazine for Club Feroviar Conferences & Technical Colloquia, Romania, ISSN: 2284-7057, pg. 80 - 87;
- Andone, I. (1994) *Sisteme Expert - Principii și dezvoltarea aplicațiilor de gestiune*, Bucuresti: Editura Tehnica, Romania;

- Airinei, D. (1995) *Problemes concernant la generalisation des systems experts dans les activites financieres et comptables*, The Proceedings of the 2-nd International Symposium of Economic Informatics, pg. 409-412;
- Iovan, St. and Litra, M. (2012) *Analysis of the Use of Information Technology in Safety Management of Rail Traffic*, Targu-Jiu: "Academica Brancusi" Publisher, Romania, *Annals of the "Constantin Brancusi" University, Engineering Series*, Issue 4/2012, (CONFERENG 2012), ISSN: 1842 – 4856, pg. 330 - 342;
- Iovan, St. and Daian, Gh.I. (2012) *Enterprise Services Architecture in the World of Information Technology*, Targu-Jiu: "Academica Brancusi" Publisher, Romania, *Revue Fiability & Durability*, Supplement No. 1/2012, (SYMECH 2012), ISSN: 1844 – 640X, pag. 375 – 381;
- Iovan, St. and Litra, M. (2013) *Use of Information Technology in Romanian Railway Traffic Management*, Sibiu: Railway PRO Science & Technology, Official magazine for Club Feroviar Conference & Technical Colloquia, Romania, ISSN: 2284 - 7057;
- Iovan, St. and Litra, M. (2013) *Developments in Freight and Passenger Railway*, Targu Jiu: "Academica Brancusi" Publisher, Romania, *Annals of the "Constantin Brancusi" University, Engineering Series*, Issue 4/2013, (CONFERENG 2013), ISSN: 1842 – 4856, pag. 149 - 164;
- Litra, M. and Iovan, St. (2012) *Innovation Process in Information Technology Used to Support for Business Processes*, Bucuresti: Proceedings of the 13th European Conference (E_COMM_LINE 2012), România, ISBN: 973-1704-22-1;
- Litra, M., Szentes, Is. and Iovan, St. (2013) *Romanian Railway Traffic Management in Relation to the European Regulations in the Field*, Sibiu: Railway PRO Science & Technology, Official Magazine for Club Feroviar Conference & Technical Colloquia, Romania, ISSN: 2284 - 7057;