



INTERNATIONAL JOURNAL OF ACADEMIC RESEARCH IN BUSINESS & SOCIAL SCIENCES



The Impact of Instagram Reels on Youths' Trust and their Holiday Intention

Azlin Zanariah Bahtar

To Link this Article: <http://dx.doi.org/10.6007/IJARBSS/v13-i1/15901>

DOI:10.6007/IJARBSS/v13-i1/15901

Received: 04 November 2022, **Revised:** 06 December 2022, **Accepted:** 26 December 2022

Published Online: 10 January 2023

In-Text Citation: (Bahtar, 2023)

To Cite this Article: Bahtar, A. Z. (2023). The Impact of Instagram Reels on Youths' Trust and their Holiday Intention. *International Journal of Academic Research in Business and Social Sciences*, 13(1), 635–641.

Copyright: © 2023 The Author(s)

Published by Human Resource Management Academic Research Society (www.hrmars.com)

This article is published under the Creative Commons Attribution (CC BY 4.0) license. Anyone may reproduce, distribute, translate and create derivative works of this article (for both commercial and non-commercial purposes), subject to full attribution to the original publication and authors. The full terms of this license may be seen at: <http://creativecommons.org/licences/by/4.0/legalcode>

Vol. 13, No. 1, 2023, Pg. 635 – 641

<http://hrmars.com/index.php/pages/detail/IJARBSS>

JOURNAL HOMEPAGE

Full Terms & Conditions of access and use can be found at
<http://hrmars.com/index.php/pages/detail/publication-ethics>



INTERNATIONAL JOURNAL OF ACADEMIC RESEARCH IN BUSINESS & SOCIAL SCIENCES



www.hrmar.com

ISSN: 2222-6990

The Impact of Instagram Reels on Youths' Trust and their Holiday Intention

Azlin Zanariah Bahtar

Senior Lecturer Faculty of Business & Management UiTM Cawangan Melaka
110 Off Jalan Hang Tuah 75300 Melaka

Abstract

Vertical video is currently the hit thing among social media users. This is because, smartphones are used vertically rather than horizontally. Seeing this, Instagram introduced Instagram Reel that is equipped with the editing functions and ability to embed music that entices the users to create attractive contents in regards to their daily activities. Moreover, the pandemic of Covid19 has come to its end which this made people globally start to resume the lives they have left behind, including to travel. Interesting and aesthetics vertical videos are uploaded and received many views especially when the accounts are not set to private. The intention of this study is to determine how the Instagram Reel Attributes influence the intention of other Instagram users specifically the youths to travel after they view the Instagram Reels on holiday contents. Findings from this study are expected to extend the literature on Instagram Reels and give benefits to marketers and the companies behind the tourism industry.

Keywords: Parasocial Interaction, Instagram Reels, Travel Intention, Covid19

Introduction

Tourism industry faced a decreasing number of tourists and visitors due to the pandemic of Covid19 (Anuar et al., 2021; Zhao et al., 2022). April 2022, the Malaysian government had announced that the nation has entered the endemic phase which many had taken the opportunity to travel to both local and abroad destinations. After being locked down for two years, social media (SocMed) platforms are filled with beautiful pictures and nice videos uploaded by the users. Recently, short videos on social media has gained its popularity (Zhao et al., 2022). People share their holiday experiences on SocMed (Han & Chen, 2021; Li, 2019; Tešin et al., 2022; Yilmazdoğan et al., 2021) out of excitements. With more than 3.5 billion of SocMed users globally (Han & Chen, 2021), we can imagine the amount of short video that could be uploaded on the platforms.

Apart from SocMed users, SocMed influencers and travel agencies use SocMed platforms more actively these days to reach out their followers and customers as part of modern and digital marketing technique (Han & Chen, 2021; Yilmazdoğan et al., 2021). They plan, prepare and upload necessary contents as a way to promote the destinations and attractions (Kwak et al., 2021; Zhou et al., 2022). Promotion on SocMed is viewed to be effective and more

reliable. Many SocMed users especially the youths perceived obtaining information on the platforms are more convenient, essential and easy to access (Anuar et al., 2021; Kwak et al., 2021; Li, 2019; Tsai & Chu, 2017). The shared contents can somehow motivate the youths to initiate their travel intention and some even rely on the contents to assist them in their traveling planning (Han & Chen, 2021; Kwak et al., 2021; Moon & An, 2022; Tešin et al., 2022).

There are many options of SocMed platforms available in Malaysia. YouTube, and Facebook are the two main platforms that have the most users and considered as the most stable platforms (Kwak et al., 2021). Meanwhile, Instagram is rising among the youths (Anuar et al., 2021) and expected to have 1.44 billion users worldwide by year 2025 (Dixon, 2022) and as of October 2022, Malaysia had approximately 15.1 million users with majority of the users are between 25 to 34 years of age and followed by users between 18 – 24 years old (Dixon, 2022; NapoleonCat, 2022).

Generally, Instagram is known and recognised as a photo sharing social network application where it manages to attract the young generation to browse and share their own contents captured using their smartphones (Anuar et al., 2021; Yilmazdoğan et al., 2021). Based on previous studies, the young generation prefer to spend more time on Instagram rather than Facebook because the application allows the users not only to instantly share their posts, but it provides tools that allowing the users to edit, and add effects on their contents before posting which will make the contents be more appealing (Menon, 2022; Yilmazdoğan et al., 2021).

To serve the users better, Instagram continuously upgrade its platforms and services. In August 2020, the platform has introduced a new built-in function; vertical video service known as Reel as to keep pace with the current trend in the social media ecosystem (Instagram, 2020; Menon, 2022). This vertical video sharing becomes a phenomenon as people are more engaging with videos (Tsai & Chu, 2017; Zhou et al., 2022). Moreover, smartphones are used vertically rather than horizontally (Menon, 2022) which will make video watching be more convenient, entertaining and pleasant.

Problem Statement

Instagram is a public platform, anyone can share their personal contents through fixed photos or series of videos including Reels (Yilmazdoğan et al., 2021). Although Reel function just launched a couple of years ago, yet the acceptance and usage has spiked (Menon, 2022). The Reel itself has been upgraded countless of times since it was introduced as to satisfy the users' preferences (Starr, 2022). Previously, Instagram allowed its users to upload the short vertical video up to only 60 seconds (Menon, 2022). However, months ago the duration has been revised where the new length is up to 90 seconds (Starr, 2022). The Reel can be viewed by everyone as long as the users' accounts are not set to private. Not only that, the users are also allowed to like, leave comments and share the Reels not only on Instagram, but on other SocMed platforms too such as on Facebook, Telegram and WhatsApp (Menon, 2022).

In the context of tourism and vacation contents, Instagram specifically Reels can definitely motivate, influence certain traveling decision and increase the tendency to travel especially among the young travellers (Anuar et al., 2021; Li, 2019; Yilmazdoğan et al., 2021). The contents available spread the choices and options of the destinations through exquisite fixed

photos and especially the nicely edited Reels alongside with well narrated descriptions that contain necessary information and authentic reviews (Anuar et al., 2021; Han & Chen, 2021; Li, 2019; Yilmazdoğan et al., 2021). From a certain angle, travel Reels can be viewed as reviews shared by the travellers; either influencers or not. As mentioned earlier, viewers can leave comments on the posted Reels which allowing interactions and engagement between two parties or with other Instagram users (Yilmazdoğan et al., 2021) which this can definitely increase the traveling likelihood. Statistics and previous studies pointed, Instagram platform is highly populated by the youths and young generation, therefore the purpose of this study is to determine the impact of the Instagram Reels on youths' intention to travel.

Literature Review

Intention to Travel

Selecting a perfect holiday destination is a complex process that requires an individual to have sufficient information (Han & Chen, 2021; Kwak et al., 2021; Yilmazdoğan et al., 2021). The advent of technology and the emergence of social media allowing necessary information to be made available online which facilitates a person in making their traveling decision (Anuar et al., 2021; Kwak et al., 2021; Tešin et al., 2022). Notably, Instagram is highly preferred in the present days especially in traveling-related information (Tešin et al., 2022). The Instagram usage keeps on increasing as the platform always has new and updated versions that make the whole platform be more fascinating and convenient. The introduction of Reels has encouraged the users especially the young ones to act creative in their traveling content creation (Menon, 2022). The content is not only current, creatively edited, rich, meaningful but also able to achieve an emotional bond that is believing able to increase a person's trust before leading them to initiate their traveling intention (Anuar et al., 2021; Li, 2019). Zhou et al (2022) reported, video shared by travellers on social media including Instagram would leave a positive impact on other Instagram users that soon lead to intention to travel. Intention to travel is refers to people who have travel plan after they have carefully conducted cognitive and affective evaluation in determining their ideal destination (Kwak et al., 2021; Li, 2019; Zhou et al., 2022).

Instagram Reel Attributes

As a platform that created mainly for photo and video sharing, Instagram is known for its simplicity and no doubt be the preferred platform among all other social media options especially among the youths. The users actively scrolling the timeline looking at the aesthetic pictures and creative edited Reels uploaded by other users. Instagram is viewed as an ideal platform for users to interact and share views on common interest; including traveling and holiday (Anuar et al., 2021). In regards to travel content, users of Instagram perceive the Reels uploaded are meaningful, informative other than visually appealing that can assist them in planning their travel trip (Anuar et al., 2021; Tsai & Chu, 2017). Li (2019) has reported in his study, short video (Reels included) and tourism has a good linkage where great short video will able leave a powerful effect, such that will influence the users to develop positive emotion towards viewed holiday destination.

Parasocial Interaction

Yilmazdoğan et al (2021) summarised parasocial interaction (PSI) as interaction that takes place between social media users which closely related to one's emotion. It is also indicating how users socially engaging and understand each other's emotion; either the person is known

or not (Zhao et al., 2022). Although PSI is generally a one-sided relationship between audiences and unknown uploaders, yet the engagements allow users to enjoy the uploaded content, and to get additional insights especially through Instagram Reels (Yilmazdoğan et al., 2021). Reels or short video shared not only be appealing and entertaining that able to capture the attention of the audiences, yet they somehow would grow fond emotion towards the content which resulting in developing trust that lead to intention to travel (Yilmazdoğan et al., 2021; Zhao et al., 2022).

Trust

Trust is part and parcel of emotion which is built based on satisfied information needs through sufficient interaction and engagements (Anuar et al., 2021). Grateful for the functions provided by Instagram, now users are able to create and edit their travel Reels and make it available for public. As we noted, customers and consumers these days prefer to view contents uploaded by non-producer (company). They perceive content shared by other people as more genuine, and legit hence be more trustworthy and trust is an important element on purchasing intention and in this context, travel intention (Anuar et al., 2021; Tobias-Mamina et al., 2020; Yilmazdogan et al., 2021).

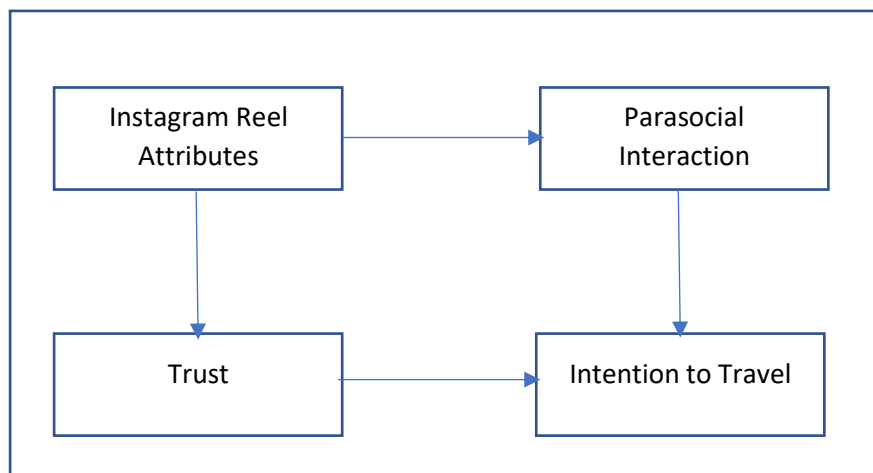

Fig 1: The Conceptual Framework

The hypotheses are as follow

H1: There is a positive relationship between Instagram Reel Attributes and Parasocial Interaction

H2: There is a positive relationship between Instagram Reel Attributes and Trust

H3: There is a positive relationship between Trust and Intention to Travel

H4: There is a positive relationship between Parasocial Interaction and Intention to Travel

Research Methodology

To collect data on the proposed model, link to a self-administered questionnaire will be shared to the potential respondents. To get respondents, the researchers will approach those who own Instagram accounts and age between 18 to 40 years old and have viewed some holiday Reels posted to participate to answer the survey questions. To ensure, only those who fit with criteria will answer the survey set, a description about the study will be made available at the beginning of the survey.

In this study, a non-probability sampling frame for the stipulated population will be undertaken based on a Convenience Sampling Procedure approach. The approach is chosen, as it would be able to facilitate the researchers in understanding the possibility of people to travel after viewing holiday Reels posted on Instagram. The answered questionnaires will be analysed using Statistical Package for Social Science (SPSS) and Partial Least Square (PLS).

Conclusion

Holiday and traveling are somewhat what everyone is looking forward to. Especially during the long holiday break at the end of the year; Christmas and New Year. Browsing social media for destination ideas has become a normal way among the youths as majority of them are looking for places not only naturally aesthetic, but must be social media worth (Instagramable) other than affordable. Therefore, nicely edited and created holiday contents on vertical videos and posted on Instagram certainly able to capture the eyes of the Instagram youth users. Viewing those reels definitely will create certain pleasure and happy feelings particularly now we all have passed the crucial period; Pandemic of Covid19.

Most people are looking forward to embrace the new phase of life and ready to explore the world. The Reels somehow is believed able to attract the audiences to spark the intention to travel. Many studies had been conducted to examine how social media can influence people's intention to travel. However, very few had been done specifically on how Instagram Reels can leave impacts on people and soon lead them to travel. Looking at the holiday planning trends among the youths, researcher believes that the finding of this study will give the travel agencies, and hoteliers some insights on how they can prepare their marketing short vertical videos. Should they focus the contents on the services they provide or benefits (experiences) the youth travellers would gain.

Reference

- Anuar, F. I., Zaid, A. A. A., Zabidi, I. Z., & Kamal, S. N. J. (2021). Young Tourists' Trust in Instagram Travel Influencers and their Intention to Visit Travel Destinations. *International Journal of Academic Research in Business and Social Sciences*, 11(16), 304–317. <https://doi.org/10.6007/ijarbss/v11-i16/11236>
- Dixon, S. (2022). *Number of Instagram Users Worldwide from 2020 to 2025 (in billions)*. Statista. <https://www.statista.com/statistics/183585/instagram-number-of-global-users/>
- Han, J., & Chen, H. (2021). Millennial Social Media Users' Intention to Travel: The Moderating Role of Social Media Influencer Following Behavior. *International Hospitality Review*, 36(2), 340–357. <https://doi.org/10.1108/ihr-11-2020-0069>
- Instagram. (2020). *Introducing Instagram Reels*. Instagram. <https://about.instagram.com/blog/announcements/introducing-instagram-reels-announcement>
- Kwak, F. Y., Teh, B. T., Michael, E., & Hamdan, F. N. (2021). Influence of Social Media on Travel Intention Among UTAR and UiTM University Students' Travel Intention to South Korea. *International Journal of Heritage, Art and Multimedia*, 4(15), 78–88. <https://doi.org/10.35631/ijham.415007>
- Li, M.-H. (2019). Exploring Short Video Application Users' Visit Intention: Applying the Stimulus-Organism-Response Model. *Asian Social Science*, 15(12), 8.

<https://doi.org/10.5539/ass.v15n12p8>

- Menon, D. (2022). Factors Influencing Instagram Reels Usage Behaviours: An Examination of Motives, Contextual Age and Narcissism. *Telematics and Informatics Reports*, 5(February), 1–10. <https://doi.org/10.1016/j.teler.2022.100007>
- Moon, J.-W., & An, Y. (2022). Uses and Gratifications Motivations and Their Effects on Attitude and e-Tourist Satisfaction: A Multilevel Approach. *Tourism and Hospitality*, 3(1), 116–136. <https://doi.org/10.3390/tourhosp3010009>
- NapoleonCat. (2022). *Instagram users in Malaysia*. NapoleonCat. <https://napoleoncat.com/stats/instagram-users-in-malaysia/2022/10/>
- Starr, L. (2022). *Update Alert: Instagram Extends Reels Length to 90 Seconds*. Planthat. <https://www.planthat.com/instagram-90-second-reels/>
- Tesin, A., Pivac, T., Besermenji, S., & Obradovic, S. (2022). Exploring the Influence of Instagram on Travel Destination Choice. *The European Journal of Applied Economics*, 19(1), 66–80. <https://doi.org/10.5937/ejae19-33584>
- Tobias-Mamina, R. J., Kempen, E., Chinomona, R., & Sly, M. (2020). The Influence of Instagram Advertising on Destination Visit Intention. *African Journal of Hospitality, Tourism and Leisure*, 9(3), 274–287. <https://doi.org/10.46222/ajhtl.19770720-18>
- Tsai, Y.-C., & Chu, C.-M. (2017). The Influence of Video Clips on Travel Intention and Destination Image. *International Journal of Arts and Commerce*, 6(1), 37–55. www.ijac.org.uk
- Yilmazdogan, O. C., Dogan, R. S., & Altintas, E. (2021). The Impact of the Source Credibility of Instagram Influencers on Travel Intention: The Mediating Role of Parasocial Interaction. *Journal of Vacation Marketing*, 27(3), 299–313. <https://doi.org/10.1177/1356766721995973>
- Zhao, C., Shen, H., & Zhang, Y. (2022). The Study on the Impact of Short Video Tourism Vloggers at Social Media Platform on Online Sharing Intention. *Frontiers in Psychology*, 13(July), 1–14. <https://doi.org/10.3389/fpsyg.2022.905002>
- Zhou, Y., Liu, L., & Sun, X. (2022). The Effects of Perception of Video Image and Online Word of Mouth on Tourists' Travel Intentions: Based on the Behaviors of Short Video Platform Users. *Frontiers in Psychology*, 13(September), 1–16. <https://doi.org/10.3389/fpsyg.2022.984240>