

Investigating the Relationship between Cultural Capital and between- Person Trusts (Case Study: Government University of ILAM)

Mohammad Hussein Askarinia¹, Ali Akbar Khalafi², Mohammad Abasi Niko³, Ehsan Namdar Joyami^{4*}**

¹M.D Marketing Trends, Department of Business management, - University of Ilam, Islamic Republic of Iran

²M.D Marketing Trends, Department of Business management, - University of Ilam, Islamic Republic of Iran

³M.D Marketing Trends, Department of Business management, - University of Ilam, Islamic Republic of Iran

⁴M.D Marketing Trends, Department of Business management, - University of Ilam, Islamic Republic of Iran

Corresponding Author: Ehsan Namdar Joyami Email: davood.joyame@gmail.com

DOI: 10.6007/IJARBSS/v5-i6/1672 URL: <http://dx.doi.org/10.6007/IJARBSS/v5-i6/1672>

Abstract:

There are many kinds of exchangeable capital in the world. This study aims to investigate the relationship between cultural capital and between- person trusts as the main variable of social capital. By examining the relationship between interpersonal trust and cultural capital, it is possible to promote the culture of trust – making among the various groups and increase the congruence of knowledge – based organizations and universities. From the goal perspective, this is a theoretical study and from data – gathering perspective, this is a descriptive – measurable study. Data was analyzed by use of SPSS 19 and LISREL 8/53 soft wares. The population included 462 employees of government university of ilam among whom 353 ones were selected as the sample using Kerjisi – Morgan's table.

Findings: Bourdieu argues that cultural capital includes 3 dimensions: embodied dimension, factual dimension and basic dimension. In this regard, there are four hypotheses showing that there is a meaningful and positive relationship between the three dimensions and between-person trusts. The degrees of Cronbach's α relative to the three dimensions are respectively %74, %92 and %83. The R – values relative to the dimensions are %59, %66 and %54. Moreover, the degree of total relationship between cultural capital and between- person trusts is %63.

Key words: Embodied cultural capital, Factual cultural capital, Basic cultural capital, between-person trusts.

1- Introduction and Statement of Issue:

In the modern era, organizations and persons take an active role in achieving goals and competing with each other. Capital is regarded as the main variable having influence on the society. In other words, society is affected by capital. On the one hand, capital is not specially belonged to the organization and society. Persons also enjoy various capitals. This is to say that there is a meaningful relationship between society, persons and capital. Organizations' and society's performance is based on the available capital.

Bourdieu argues that capitals are interchangeable (poorJafar and MahmoodiNejad, 2009, p.19). Therefore, this study is aimed to investigate the relationship between the variables in order to interchange the available capitals and correlate them to each other. On the other hand, trust is another variable needed for developing creative structures and establishing specialized work groups in all social fields (Guise, 2009). In doing so, the between- person dimension of social capital is of great importance and it is necessary to investigate the relation between such dimension and the variable cultural capital in order to prepare the fields of trust among the members of the group and encourage them to participate in search – oriented organizations. Moreover, it is necessary to empower the work groups in order to achieve organizational goals (Azkyavli and Ghafari, 2005). Results show that it is possible to assist members of the group to have confidence in each other and increase the productivity of knowledge – based organizations by examining the relationship between cultural capital and between- person trust.

2- Review of literature

2-1- Capital:

Pear Bourdieu believes that there are three kinds of capital: (a) economic capital which refers to the person's assets and savings; (b) cultural capital which refers to the person's education and specialty ,and (c) social capital which refers to the potential resources created by the basic relations of the persons (I.e. the profits achieved form group partnership) (Ports, 1998,P.3).

Capital is referred to the accumulated wealth of each person. It is time consuming to accumulate capital. But when persons do so, they can invest it (Jenkins, 2005, P.101).

Characteristics of capital:

1-In comparison to the other kinds of capital, economic capital is rapidly changed into other capitals.**2-** Moreover, social capital is consumed quickly. **3-**The most stable kind of capitals is cultural capital (Bourdieu, 1992, P.119).

2-2- Social capital:

Social capital is referred to the daily assets appeared in the shape of friendship, congeniality and social relations of persons and family members (Suleiman, 2008). fokoyama writes: "social capital is referred to power by which persons are forced to be united in supporting their joint

needs and improving their social relations (Fokoyama, 2002). Jams Colman argues that social capital is a part of social structures by which persons are able to achieve their assets. Social structures include duties, expectations, and customs and per formative guarantee due to which the persons' behaviors are encouraged or prohibited. He believes that social capital empowers persons to do their works better (Colman, 2008, p.462 – 470). Bourdieu defines social capital as a set of potential resources resulted from participating in a work group. In reality, there should be a special positive trust – based linkage among the persons. He believes that there are three kinds of capital: economic capital, cultural capital and social capital (Poorjafar and MahmoodiNejad, 2009, P.19). Robert Putnam defines social capital as a between-person linkage (social networks) from which trust and mutual feedback criterions are rooted. To his opinion, it is impossible to have social partnership without observing citizenship rights (Share pour and poor jafar, 2005). Regarding the terms social trust, social integration and social partnership as the tree elements of social capital, Alvani and Shairvani (2001) have studied the variable social capital of Kashan city. Authors have defined the elements of social capital as the followings:

2-2-1 social trust: this is to say that social relations and agreements are shaped on the basis of social trust. Social trust creates a cooperation by which the persons' problems are solved and they are obliged to the society. The more social trust, the more persons' partnership in social fields will be.

2-2-1-1 between- person trusts: it means to be in communication with each other.

2-2-1-2 Structural trust: it means to be accepted by people of the society.

2-2-2- Social constancy: Email Doric is one of the socialists who studied social constancy and relation. From his viewpoint, social constancy is one of the main elements of each society. Jonathan Tenner writes: “constancy is occurred when persons’ emotions are regulated by cultural symbols. It occurs when persons are linked to the society and the social costumes are regulated by them.”(Akbari, 2004).

2-2-3 Social partnership: Alan Byroad argues that social partnership is referred to enjoying something or participating in group works. Donald Michel says that people trust themselves when participate in decision makings about their life (Azimi and Ramezani, 1998, p.47).

2-3- Cultural capital:

From philosophic perspective, cultural capital is referred to basic hypotheses patterns developed by the members of a group in order to solve problems (Live, 2010). In definitions, culture refers to the person’s concrete pattern of life which includes some special technologies (Swindler, 1986).

Smirked (1966) believes that cultural capital is a set of social resources related to philology styles, pattern of authority, habits condition and family symbols (Lareau and weiniger, 2003). M.C.Doña (1997) regards cultural capital as a symbol for recognition of ignored values in the schools (Lareau and weiniger, 2003). Rey (1998) argues that cultural capital is a spread system

which includes philology capabilities, customs and priorities regarded as the aspects of culture. Balked (2001) regards cultural capital as the cultural resources by which family members can match with school's rules. Carter (2003) defines cultural capital as a set of characteristics, secrets and cultural symbols. Lareau and weiniger (2003) argue that cultural capital is referred to the capability of social position in presenting valuable standards for evaluation of education systems. bourdieu believes that there are three types of cultural capital: embodied cultural capital, factual cultural capital and basic cultural capital (Bourdieu and Passeron, 1990).

2-3-1- Embodied cultural capital: refers to the knowledge and capabilities of persons. In reality, it refers to the potential abilities of persons (Nogani, 2005). Such behavior is a part of their personalities and it is impossible to change it (Niazi et al, 2007).

2-3-2- factual cultural capital: refers to all cultural goods by which all owners are educationally affected (e.g. the number of books and magazines of a library, being a member of library, the number of books , newspapers and magazines bought by persons)(Mohseni, 1998).

2-3-3 Basic cultural capital: in cludes talented persons who have various educational degrees. On the other hand, basic cultural capital is related to formal institutions issuing educational documents. It is impossible to transfer such capital (Amini, 1986, P. 118).

3- Background:

Until now, there is no evidence relative to the relationship between cultural capitals and between – person trusts. It is worth noting that the current study aims to investigate the relationship between the two variables for the first time. In recent years, share pour's (2002) work focuses on the relation between various aspects of cultural capital and also the relation between cultural capital and various social identities. Results show that there is a positive relationship between such variables. Niazi et al (2007) studied the relation between cultural capital and social identity of the youth of Kashan. From the results, it became clear that there is a meaningful relationship between the two variables. Salarzadeh and Mahboobi (2009) investigated the relationship between social capital and educational success among the students of uromiye. Fred Ericson (2009) concluded that those who experience feeling of joy live more years and have more positive social relations with others.

Results of Amjadian's study show that persons who lose their hope are more affected by social relations (2005). HezarJoreibi and Safary (2009) concluded that the variable hope to social future influences on satisfaction level. In other word, the more hope to future, the more life satisfaction will be.

4- Methodology:

This is a theoretical – descriptive study in which data was analyzed by use of **SPSS 19** and **Lisrel 8/53** soft wares.

4-1- Population, sample and instrument government:

The population included 462 employees of government university of ilam. Sample included 355 persons. Data was gathered by use of Likret’s questionnaire. The questionnaire included 19 elements relative to the variables embodied cultural capital (5), factual cultural capital (5), basic cultural capital (4) and between – person trust (5).

4-2- Reliability and credibility:

Reliability and credibility of the questionnaire was evaluated by use of SPSS software and Cronbach’s α ($\alpha= /87$).

Table 1 – Cronbach’s α value:

	Embodied	Factual	Basic	Total cultural capital
Between – person trust	0/74	0/92	0/86	0/87

4-3- General purpose:

This study is mainly aimed to investigate the relationship between cultural capital and between – person trusts.

4-4- Sub – purposes:

- 1- Investigating the relationship between embodied cultural capital and between – person trust
- 2- Investigating the relationship between factual cultural capital and between – person trusts.
- 3- Investigating the relationship between basic cultural capital and between personal capital

4-5- Main hypothesis:

There is a meaningful relationship between variables cultural capital and between – person trusts.

4-6- sub – hypotheses:

- 1- There is a meaningful relationship between embodied cultural capitals and between – person trusts.
- 2- There is a meaningful relationship between factual cultural capitals and between – person trusts.
- 3- There is a meaningful relationship between basic cultural capital and between – person trusts.

4-7- Research meaning – based model

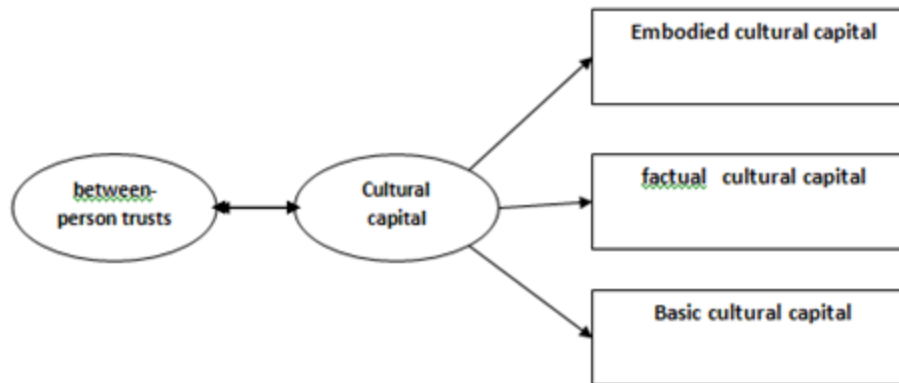

5. Data analysis:

Data was analyzed by use of Lisrel 8/53 software and hypotheses were tested by use of structural equation modeling.

Before testing hypothesis, it is necessary to test the models of measuring variables. In doing so, the models are selected by use of confirmed factor analysis approach. Factor analysis is one of the main statistical approaches used for investigating the relation between various variables.

5-1- Independent variable measuring model

In this study, cultural capital is considered as the independent variable. Because this is a two – step variable, it is necessary to use two confirmed factor analysis approaches. At first step, it is possible to find dimensions based on the questions and at the second step, it is possible to find the main variable based on the dimensions.

5-1-1 Results of first – step factor analysis

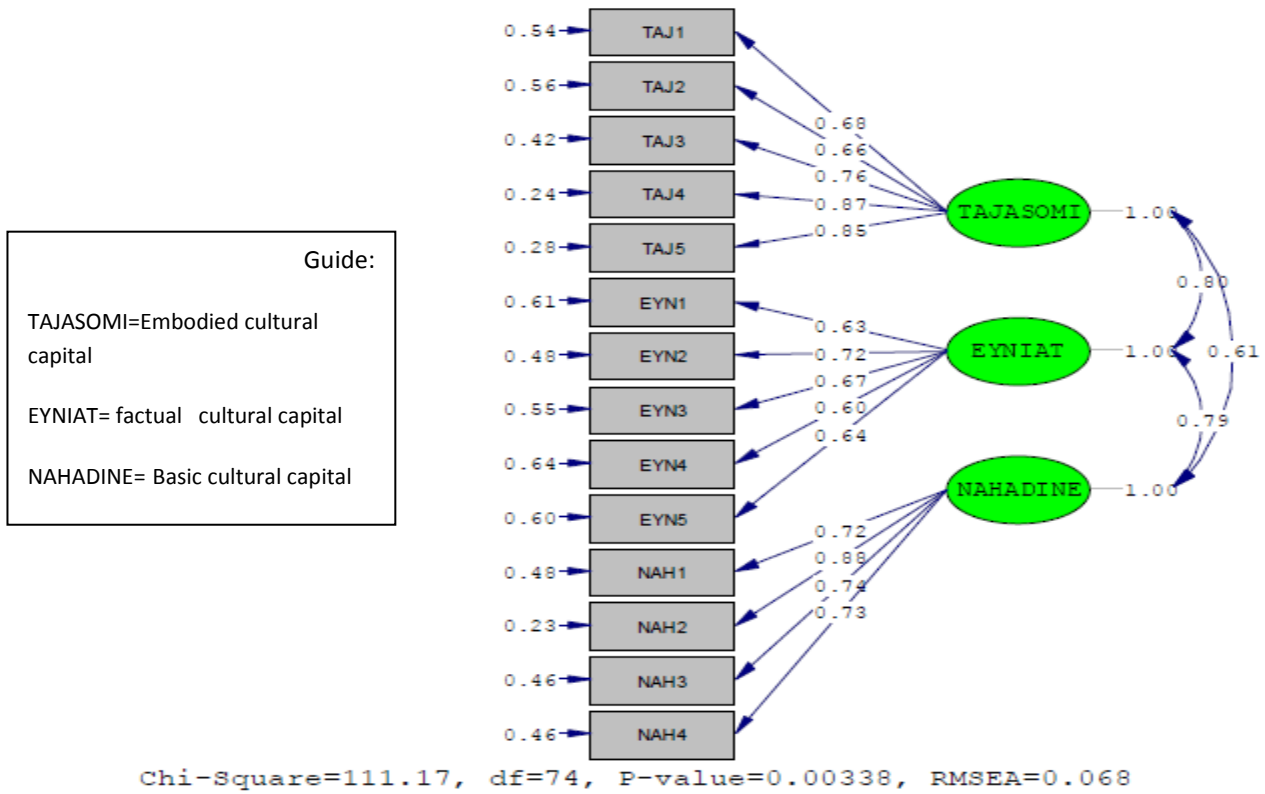

Figure 1: Independent variable measuring model

The relationship between dimensions and questions is called factor loading. All factor loadings should be more than 0/5. As seen above, all factor loadings relative to the dimensions are bigger than 0/5. Then, this is to say that all dimensions have been correctly evaluated.

5-1-2- Results show that such measuring model is suitable and all parameters are meaningful. Moreover, there is a positive and meaningful relationship between the dimensions of cultural capital.

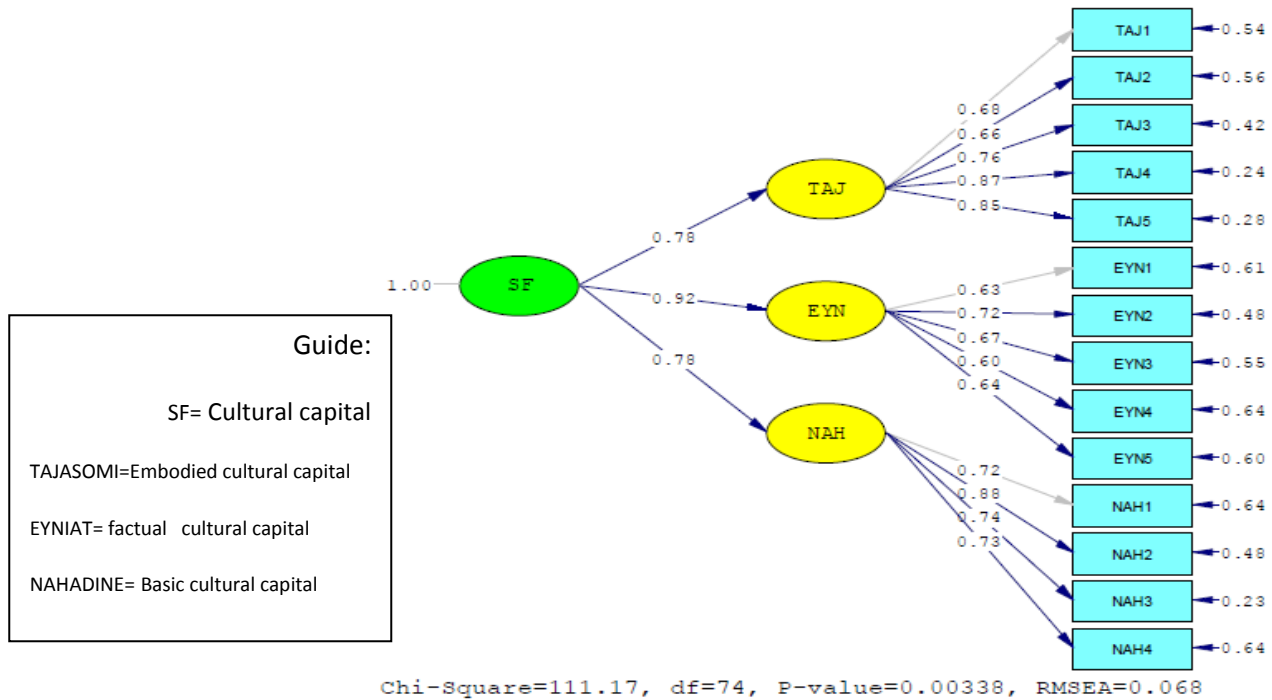

Figure 2: Independent variable measuring model

5-2- Dependent variable

Dependent variable (between – person trust) of the study is dimensionless and is directly evaluated by the questionnaire. Results show that the measuring model related to the endogenous variable is suitable and parameters are meaningful.

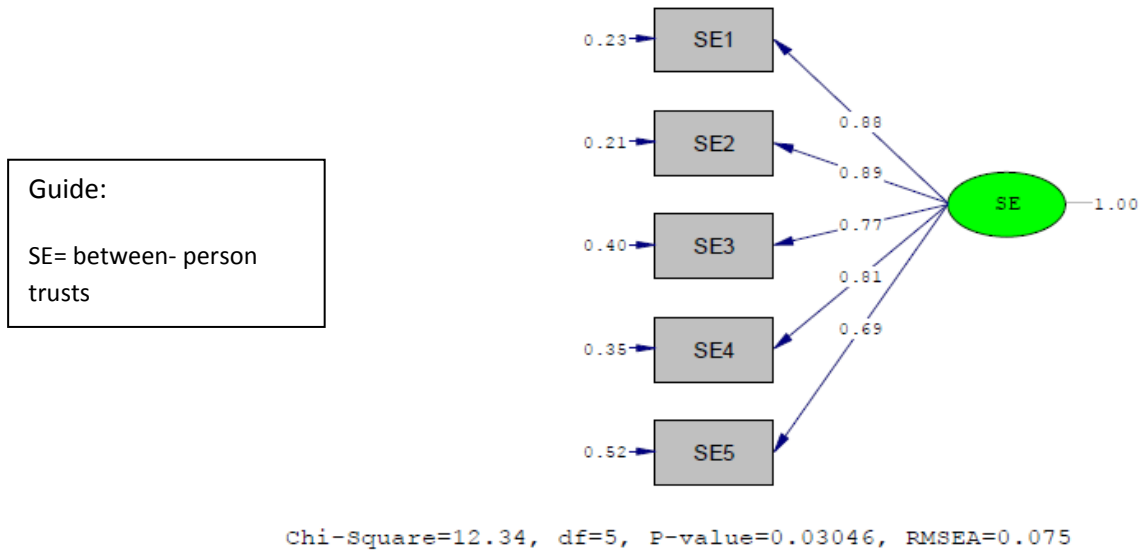

Figure 3: factor analysis relative to the variable between – person trusts Results show that the measuring model is suitable and all figures and parameters are meaningful.

5-3- Main hypothesis model

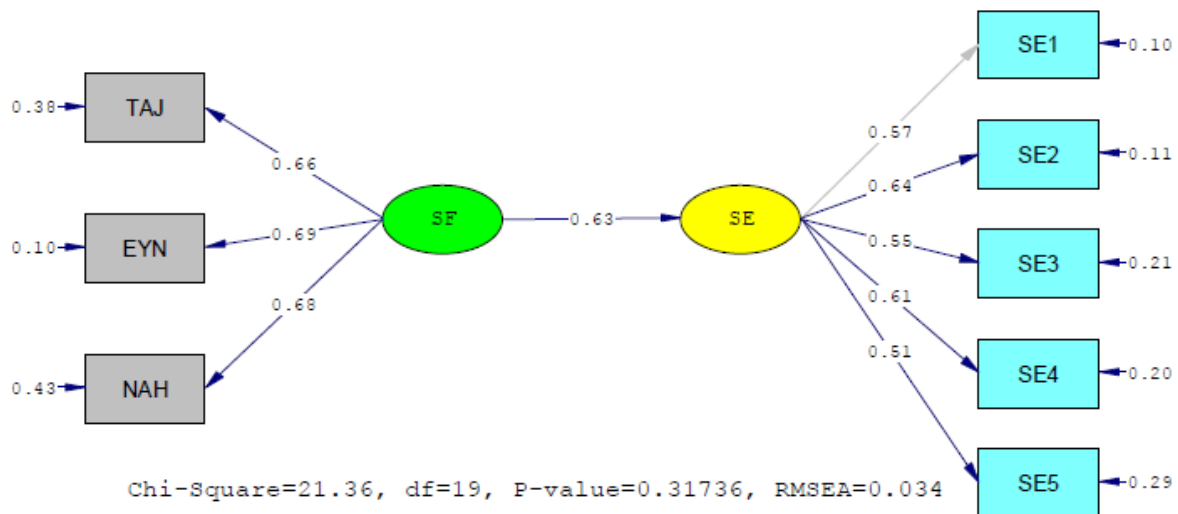

Figure 4 – Meaningful model of the main hypothesis (standard estimation).

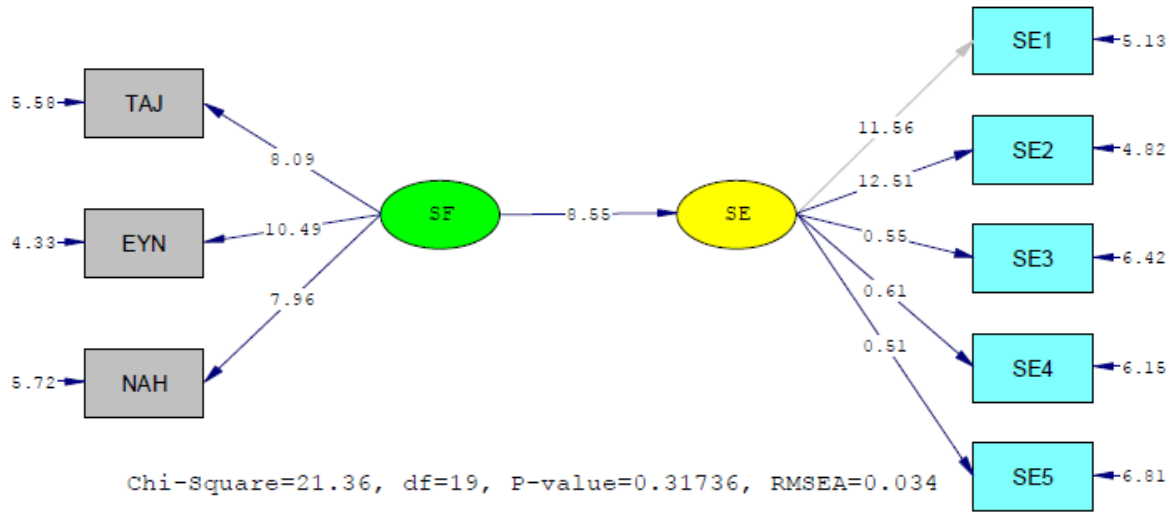

Figure 5 – meaningful model of the main hypothesis (meaningful coefficients)

5-4- sub – hypothesis models:

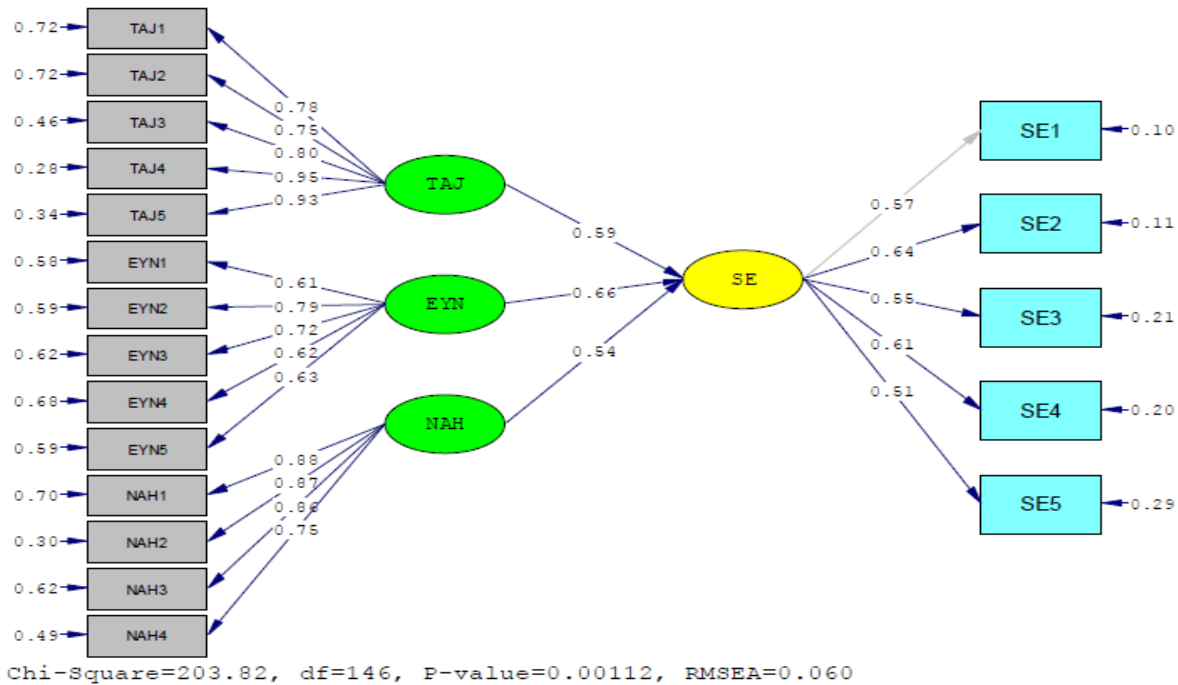

Figure 6 – meaningful model of sub – hypotheses (standard estimation)

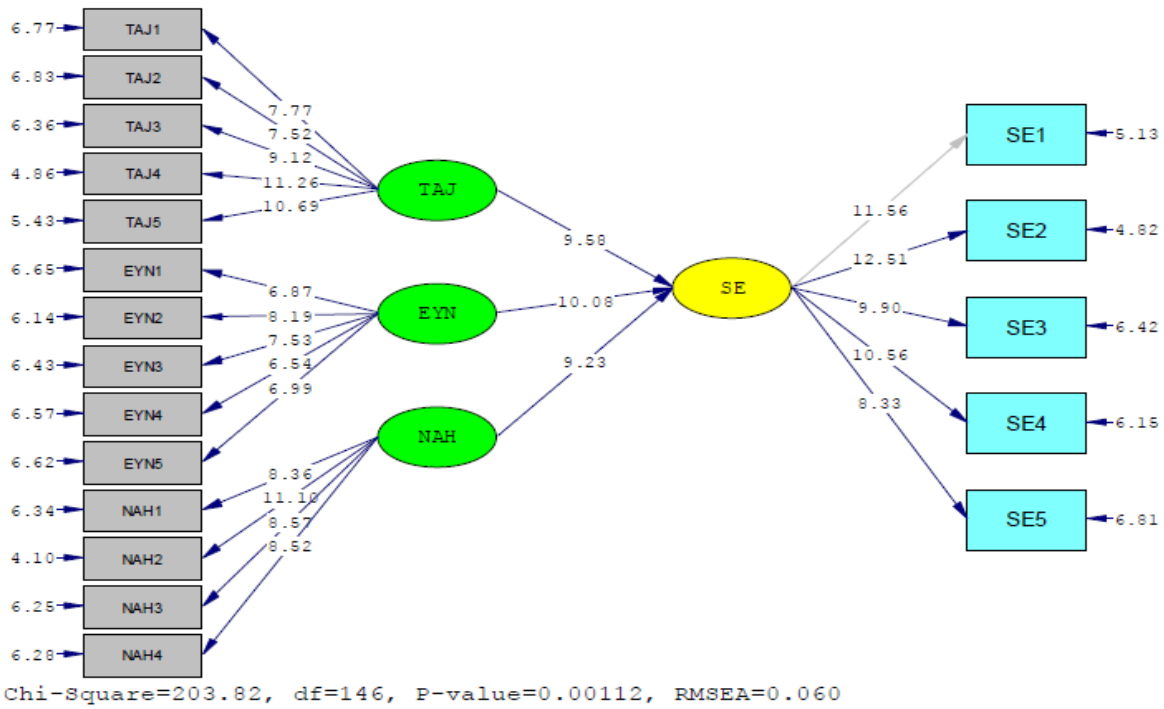

Figure 7 – meaningful model of sub hypothesis (meaningful coefficients)

5-5 Hypothesis test:

Table below shows the criterions χ^2 , RMSEA and GFI. Due to the table, the model is suitable when $\chi^2/df < 3$, $RMSEA < 1$ and $GFI/AGFI > -2 > T > 2$.

Table 2: The results of structural model of the variables

Hypothesis	χ^2	RMSEA	OF	GFI	AGFI	Relations between	Effect level	T	Result
Main	21/36	0/034	19	0/97	0/94	Cultural capital between – personal trust	0/63	8/55	Accepted
Sub – h1	203/82	0/060	146	0/96	0/95	Embodied cultural capital – between personal trust	0/59	9/58	Accepted
Sub – h2	203/82	0/060	146	0/94	0/96	Factual cultural capital – between personal trust	0/66	10/08	Accepted
Sub – h3	203/82	0/060	146	0/95	0/92	Basic cultural capital – between personal trust	0/54	9/23	accepted

As seen above, the model is reliable because t – value is meaningful, χ^2 and $RMSEA < 90$ and $AGFI/GFI > 90$. This is to say that all hypotheses are accepted.

6- Findings:

As noted before, this survey is aimed to investigate the relation between cultural capital and between – person trusts. In so doing, there are four hypotheses. The hypotheses are discussed as follows:

Sub – hypothesis 1: There is a meaningful relationship between embodied cultural capital and between – person trusts.

This hypothesis is accepted because $\alpha = 74$ and $R = 59$.

Sub – hypothesis 2: there is a meaningful relationship between factual cultural capitals and between – person trusts.

The hypothesis is accepted because $\alpha = \%92$ and $R = \%66$.

Sub – hypothesis 3: There is a meaningful relationship between basic cultural capital and between – person trusts.

The hypothesis is accepted because $\alpha = \%86$ and $R = \%54$.

Main hypothesis: There is a meaningful relationship between cultural capitals and between – person trusts.

The main hypothesis is accepted because there is a direct and positive relation between the dimensions of cultural capital and between – person trusts. Therefore, this is to say that there is a meaningful relationship between cultural capital and between – person trusts. Due to the results, $R = \%63$ and $\alpha = \%87$.

7- Conclusion:

In result, this is to say that the more cultural capital, the more between – person trusts will be. Those having more cultural capital have positive view toward the others' behavior. Therefore, such persons are more prosperous in decision makings and can play a positive role in having relation with others.(The results show that people who have higher cultural capital (embodied, objectified, institutionalized) interpersonal trust them more and show that it is definitely a more positive view of the world are watching and their close relatives have a lot of confidence. These people form groups and work teams are successful and effective role, which led to greater empathy and solidarity among members of the group will be).

The researchers recommended that in future, this relationship in the community outside the university and within the community (general public (cultural capital below)) or at other universities (and other organizations with high cultural capital) were investigated and the results with this investigation are compared.

References :

- Akbari, A. (2004), rural development by emphasizing on rural society of Iran, Tehran, Nei publication.
- Akbari, A. (2004), the role of social capital in partnership – the influence of social capital on social partnership, Tehran.
- Alvani, S.M. (2001), Shirvani Ali Reza, official reformation and social capital,managemtn and development, No.10.
- AzimiRamezani. (1998), the role and importance of partnership in developing educational management.
- Azkia, M, Gafari, G. (2004), rural development by emphasizing on rural society of Iran, Tehran, Nei publication.
- Baker,M. (2010), management and social capital, translated by Mahdi Alvani and Mohammad Reza Rabiee, Management organization, Tehran.
- Bourdieu, p. (1992),an Invitation to reflexive sociology,(University of Chicago press and polity press).

- Bourdieu, P., Jean Claude P. (1990), "Reproduction in education, society and culture, sage Publications Inc, ISBN. London.
- Bourdieu, P., Wacquant, L. (2002), An Invitation to reflexive sociology, Polity Press, p.10-45.
- Bourdieu, P. (1986), The Forms of capital. In J.G. Richardson (ed), Handbook of theory and research for the sociology of education, New York: Greenwood, (pp.241-258).
- Fakoochi, N. (2007), Pierre Bourdieu; social sciences magazine, Ferdosi university of Mashhad, P.141-161.
- Fine, B. (2010), social capital and social theory, Mohammad Kamal Sarvarian, Tehran.
- Fukuyama, F. (2000), The end of order, translated by Golam Abbas Tavasoli, the Iranian society publication, Tehran.
- Fowler, J.H., Christakis, N.A. (2008), Dynamic spread of happiness in a large social network: longitudinal analysis over 20 years in the Framingham heart study: British medical journal, 337-338.
- Frederickson, B.L. (2009), positivity: Ground breaking research reveals how to embrace the hidden strength of positive emotions, overcome negativity and thrive. New York: Crown Publishing.
- Guiso, L., Sapienza, P., Zingales, L. (2009). The Role of social capital in Financial Development, <http://www.Faculty.chicagobooth.edu/Finance/paper/trust.pdf>. Retrieved Oct 29, .
- Jankinz, R. (2012), Pierre Bourdieu, translated by Leila Javafshan and Hassan Chavoshian, Tehran, Nei publication.
- Kolman, J. (1998), Basics of social theory, Manochehr Saboori, 1998, Tehran, Nei publication.
- Lareau, A., Weiniger, E.B. (2003), cultural capital in education research: a critical assessment, theory and society 32, 567-606.
- Lin, N., Bunnie H. Ericson, (2008), social capital and Development: The coming Agenda, SAIS Review vol. xxII no.1.
- Liu, J. (2010), culture and Knowledge Transfer: Theoretical considerations, J. Service Science & Management, 3:159-164.
- Niazi, M., Karkonan, M. (2009), The relation between social capital and social identity of youth.
- Poor J., Farzbod, M.R. (2005), the results of road construction in Tajrish, Safeh Magazine.
- Poor J., MahmoodiNejad, M. (2009), Urban design and social capital in public environments, Hel Tahan publication, Tehran.
- Ritz, G. (2009), sociology theory in modern era, Mohsen Salasi, Tehran, scientific publication.
- RohalAmini, M. (1996), cultural field, Tehran, Atar publication.
- Salarzadeh, N., R. (2009), comparison of the role of social capital and socio economic institutions of Uromia, social sciences, No:44.
- Sharepour, M., Khosfar, G., R. (2002), the relationship between social identity and cultural capital, No:20.
- Sharepour, M. (2004), aspects of social capital and related consequences, social Issues of Iran, Tehran, sociology institution of Iran.
- Soleymani, M. (2008), evaluation of social capital effect on the economic growth of Iran, Imam Sadegh university.

Stoner, R .(2011), socialists, translated by: Mehrdadmirdamadi, Tehran, Nei publication.

Swindler, A. (1986), culture in action: symbols and strategies, American sociological review, s vol,51,no.2(Apr,1986).pp.273-286.

Tenner, J,H. (2009), sociology theory, translated by Abdol Ali Lahsae, 2003, Shiraz, Navid publication.