

Effect of Rubberised Engineered Cementitious Composite (R-ECC) Application as Retrofitting Material on the Structural of Reinforced Concrete Beam-Column Joint Subjected to Static and Cyclic Loading

Nor Wahida Azmin, Mohd Ikmal Fazlan Rozli@Rosli, Kay Dora Abd Ghani, Atiqah Abdul Aziz, Noorliyana Zakaria, Nor Asyiqin Jafri

Centre for Civil Engineering Studies, University Technology MARA (UiTM), Cawangan Pulau Pinang, 13500 Permatang Pau, Pulau Pinang Malaysia
Corresponding Author Email: ikmal601@uitm.edu.my

To Link this Article: <http://dx.doi.org/10.6007/IJARBSS/v14-i9/23015> DOI:10.6007/IJARBSS/v14-i9/23015

Published Date: 26 September 2024

Abstract

The beam-column junction in reinforced concrete structures was crucial for structural integrity due to extreme shear stress, and failure can potentially destroy a building. This study aims to determine the crack behavior, load versus displacement, ductility, and equivalent viscous damping of beam-column joints before and after retrofitting with Rubberised Engineered Cementitious Composite (R-ECC) under cyclic load test. The study examines the use of scrap rubber tyres as a partial aggregate substitute. Preparation retrofitting work used 5% of R-ECC by using the R-ECC jacketing and patching method. Research shows that R-ECC retrofitting work enhances reinforced concrete structure's crack behavior and structural performances to higher displacement. Additionally, the cyclic resistance of beam-column joints is greatly increased.

Keywords: Rubberised ECC (R-ECC), Engineered Cementitious Composites (ECC), Crumb Rubber, Used Tyre, Sodium Hydroxide (NaOH).

Introduction

Reinforced concrete beam-column joints are one of the essential components of structural elements in a building due to their susceptibility to high shear stress. The joints between the two structural members may grow brittle and fail, which would reduce the building's structural stability. To strengthen the concrete behavior, ECC seemed to be used in this study. Other ingredients in ECC include cement, fly ash, quartz sand, silica sand, and sand. The element that gives concrete its exceptional durability, however, is very different. (Al-Fakih et al., 2021).

Scrap tyre production is increasing at an alarmingly fast rate. The use of toxic disposal methods leads to significant environmental problems. However, these issues can be mitigated by incorporating recycled rubber tyres into products like bitumen and concrete by replacing a portion of the aggregate. Using crumb rubber as a partial substitute for fine aggregate in ECC is a novel strategy that is the focus of extensive scientific study and discussion (Alaloul et al., 2020).

Southeast Asia experiences frequent earthquakes. Most structural cracks and little damage occurred in Malaysia. Indonesia has the most destructive earthquakes, destroying thousands of homes. The Philippines experiences 90% of seismic events, with deep to intermediate earthquakes causing most structural damage. Over 90% of earthquakes in Indonesia, Philippines, and Myanmar devastated infrastructure, with potential tsunamis, volcanic eruptions, or landslides. Initial landslides in Sg. Mesilou and landslides on Mount Kinabalu caused fatalities and structural damage (Yousf et al., 2016).

Experimental research was done on R-ECC beam-column joints in a lab setting to find out the crack behavior of the joint subjected to lateral cyclic loading. The study also assessed the structure performances of the joint in terms of ductility and equivalent viscous damping before and after retrofitting with R-ECC jacketing subjected to cyclic load. The main goal of the beam-column joint is to maintain structural strength and to effectively defend against seismic loads. Due to the substantial amount of force lost in the joint, the beam-column joint needs to be sufficiently ductile and have suitable anchorage (Nagaraju & Reddy Suda, 2022). R-ECC materials were an excellent choice because of their high ductility, cracking behavior, deformability, and energy dissipation properties.

Methodology

Preparation of Beam-Column Joint

The beam-column joint detailing was created from the soft-storey vista as shown in Figure 1 and Figure 2. The beam-column joint structure was designed in accordance with BS8110. For the nominal cover ($c = 20$ mm), concrete strength ($f_{ck} = 35$ kN/mm²), and steel strength ($f_{yk} = 460$ N/mm²), this beam-column joint structure was employed. The dimensions of the beam are 150 mm × 150 mm × 705 mm, and the top and bottom diameters of the bar are 2T6. Meanwhile, the top and bottom of the bar's column number and diameter are 4T10, and the column dimensions are 150 mm by 150 mm by 1550 mm. For the cyclic load test machine, an analytical calculation for a column's ultimate load capacity ranges from a minimum of 10 kN to a maximum of 1000 kN.

The beam samples were structural elements capable of supporting transverse external loads and composed of reinforced concrete. The loads cause bending moments, shear forces, and torsion across their length. Additionally, concrete exhibited strong compression properties but was relatively weak in tension.

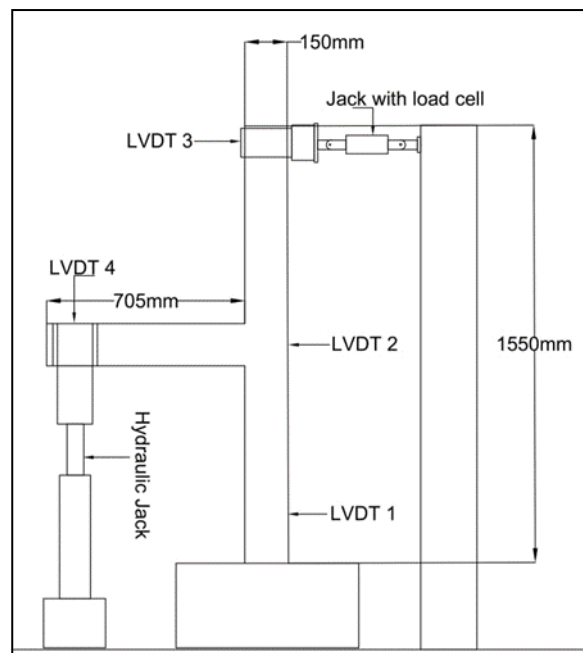

Figure 1. Test Configuration of The Beam-Column Joint

BEAM		
	TOP BAR	2T6
	BOTTOM BAR	2T6
	LINK	T6 - 75
	BEAM SIZE	150 X 150
COLUMN		
	MAIN BAR	4T10
	OUTER TIES	T6 - 75
	COL. SIZE	150 X 150

Figure 2. Beam-Column Reinforcement Size Detailing

Next, the study proceeds to casting the models of concrete. The concrete grade used in this experiment was G30. Design and preparation came first in the overall process for casting a beam-column joint. Based on the demands of the structural design, the needed dimensions, reinforcing details, and load-bearing capacity of the beam were determined. Figure 3 shows the casting process of the beam-column joint.

The beam-column joint was shaped using mould or formwork. The placement of reinforcement positioned correctly, with a clear covering, and with enough space inside the formwork, as shown in Figure 3(a). Tie wires or rebar chairs were used to hold the rebars in

place to maintain the necessary concrete cover. Subsequently, the blended concrete was gradually poured into the formwork, ensuring a uniform flow to prevent segregation as shown in Figure 3(b). Figure 3(c) shows the vibrators were among the appropriate tools used to compact the concrete and remove air spaces. The entire of the beam's volume was guaranteed to have proper compaction. To achieve the desired finish, the concrete's exposed surface was smoothed with a trowel or float. After that, the samples were cured for 28 days as shown in Figure 3(d), and adequate moisture during the curing process was maintained until the day of testing.

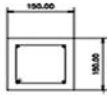
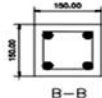

(a) Installing Reinforcement Bars in The Formwork

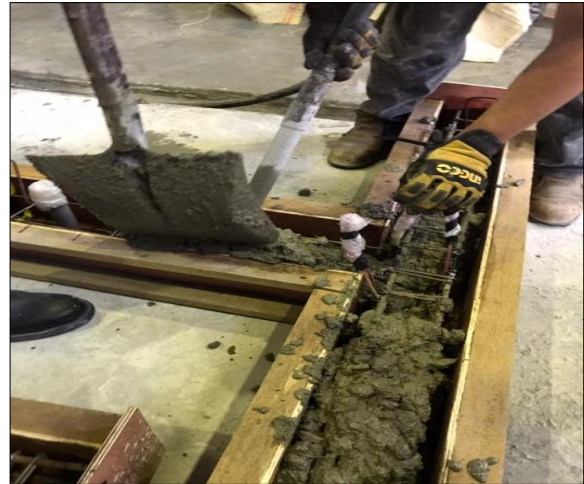

(b) Concrete pouring into the formwork



(c) Vibrating Concrete Process



(d) Casting and Curing process of R-ECC

Figure 3. Casting Process of Beam-Column Joints

Experimental Work

After being cured, the samples were tested, proving lateral cyclic load. Beam-column joint specimens were subjected to cyclic loading with a maximum load of 1000 kN using a reaction frame machine. This experiment was conducted at UiTM Shah Alam's Heavy Structural Laboratory. Figure 4 shows the test setup with the hydraulic seismic load applied vertically at the top of the column and horizontally at the beam because seismic loading was applied to the structural system at the top of the column in a horizontal manner.

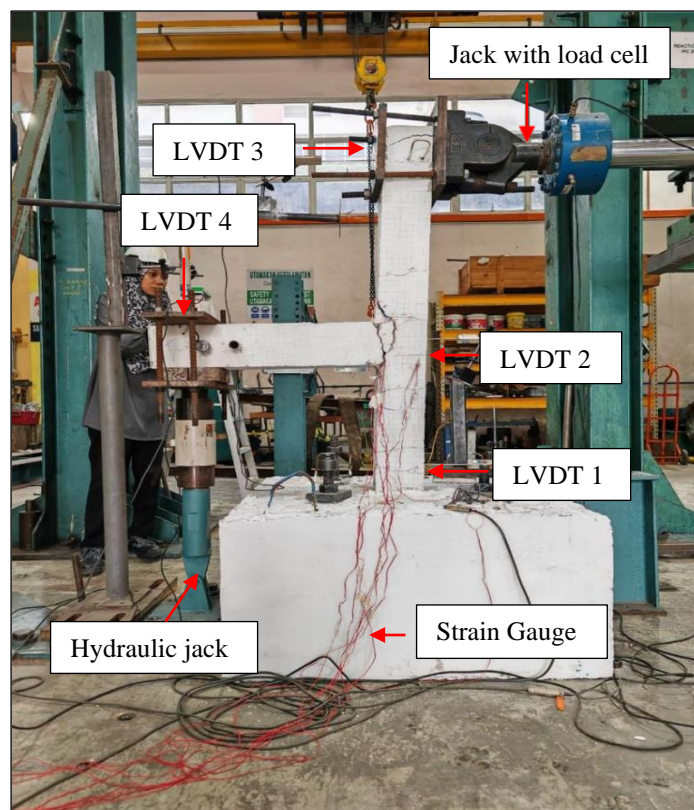

Figure 4. Beam-Column Joint During The Lateral Cyclic Loading Test

The loading regime was assigned to each specimen's sub-assemblages through the application of the control displacement technique. The displacements for each specimen were calculated considering the given drift percentages. An initial drift of 0.10% was used in the testing method, and subsequent drifts of 0.1%, 0.15%, 0.2%, 0.25%, 0.5%, 0.75%, 1.00%, 1.25%, 1.75%, 2%, 2.25%, 2.5%, 2.75%, 3%, 3.25%, 3.5%, 3.75%, 4%, 4.25%, and 4.5% were also used. At the end of the process, sample 1 had an initial drift of 4.5%, and sample 2 had a drift of 2.5%. The test was run once for every drift level to guarantee precise data collection (Kay Dora et al., 2020.)

For gathering data, LVDT sensors and strain gauges were mounted on a sample beam-column joint and connected to a computer. It was determined which places on the beam and column would work best for measuring displacement using LVDT sensors. After that, the wiring from the strain gauges and LVDT sensors was linked to a computer so that the software

on the computer could show the collected data. This allowed the rotation values to be recorded.

In order to prevent loading from continuing after cracks began to show, it was carefully managed. This allowed for the precise recording and analysis of the load and deflection at the beam-column junction at that place. Utilising LVDT sensors in conjunction with a strain gauge allowed for a comprehensive comprehension of the behavior and performance of the structure during the loading process.

Beam-Column Joints Retrofitting Work

In the laboratory, beam-column joint component was prepared for lateral cyclic loading. Every beam-column joint unit was put through a test procedure until it broke or failed. Figure 5(a) shows the fracture beam-column joint following lateral cyclic load testing, and Figure 5(b) illustrates the use of a concrete seal to patch the crack location. Sledgehammers and impact hammers were employed to roughen the surface, as seen in Figures 5(c) and 5(d). The goal was to make sure the sample's base lining stuck to it. Figure 5(e) shows the base lining mixing process with a concrete mixer, and Figure 5(f) shows the water spraying of the sample to remove dust. The concrete mixer-mixed base lining mix is shown in Figure 5(g), and the 10 mm thick base lining applied to the affected area is shown in Figure 5(h). Utilising ECC in a line-based ratio, Sika Latex 118 was employed. A base lining was put on the concrete surface. The base lining was used to bond R-ECC to the existing concrete. Next, use a concrete pan mixer to mix for R-ECC, as shown in Figure 5(i). Installing formwork with 20 mm of thickness on the sample and filling the R-ECC into formwork is shown in Figure 5(j). In order to repair and patch concrete bonding with the retrofitted material, R-ECC of 5% was used at the removal area.

Firstly, the dry components (fly ash, sand, crumb rubber, and composite Portland cement) were added to the pan mixer and blend together. The superplasticiser was added and mixed with half of the water. The remaining water and polyvinyl alcohol (PVA) fibres were gradually added and mixed until a homogenous and uniform mixture was achieved. The mixtures were then cautiously poured into the prepared moulds.

After its placement in the formwork, the R-ECC vibrated. Figure 5(k) shows a sample of the beam-column joint after R-ECC retrofitting. After applying R-ECC for 24 hours the mould was opened. Figure 5(l) shows the testing after being retrofitted for sample 2 using lateral loading frame actuator systems.

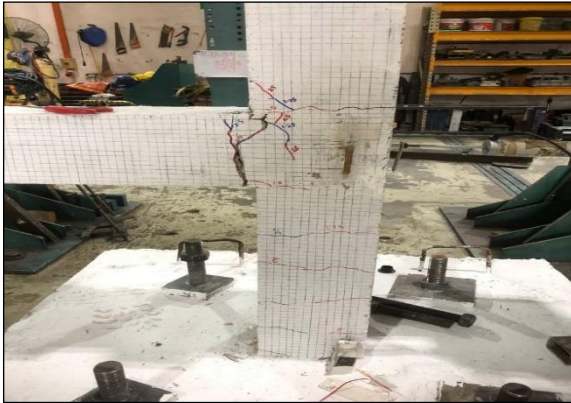

(a) Sample After Lateral Cyclic Load Testing



(b) Repairing The Crack Area Using Concrete Seal



(c) Roughness The Surface Using a Sledgehammer



(d) Roughness The Surface Using Impact Hammer



(e) Installing Wire Mesh

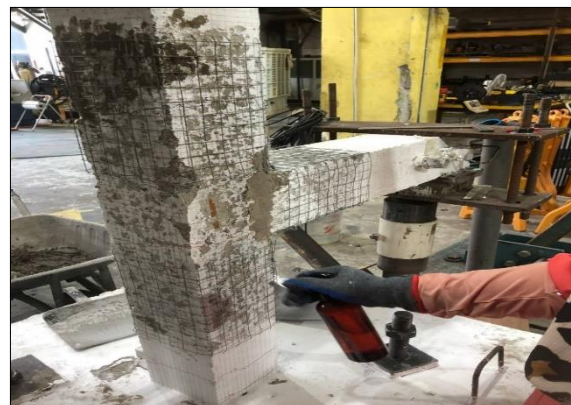

(f) Sprayed The Sample with Water to Remove Dust



(g) Mix for Base Lining Using Concrete Mixer



(h) Applied Base Lining with 10 mm of Thickness at The Sample



(i) Mix for R-ECC Using Concrete Mixer Pan



(j) Install Formwork and Fill RECC into Formwork with 20 mm of



(k) Open Mould After 24 hours
Apply R-ECC



(l) Testing After Being Retrofitted for
Sample 2

Figure 5. Experimental Work of Beam-Column Joints

Results & Discussion

Two beam-column joints units were prepared for lateral cyclic loading in the lab. A test procedure was used to test each beam-column joints unit until it fails or cracks. Results and discussion provide details on how each finding is justified. The reason is being provided to confirm the accuracy of the findings in relation to the study's initial goals. This study obtained the effect of R-ECC application as retrofitting material on the structural performance of beam-column joints.

Load-Displacement

The load-displacement curves show a linear relationship between load and displacement in all specimens. Figure 6(a) and Figure 6(b) show load-displacement graphs before and after retrofit for sample 2. In general, samples that had R-ECC reinforcements were able to reach larger displacement levels than samples that did not. Under cyclic loads, the behavior of beam-column joints with R-ECC reinforcement was examined in the study. Specimens were loaded until capacity was attained and the yield point was reached.

The load versus displacement for combinations of these links, brittle links, and ductile links. Both elastic and non-linear behavior can be obtained in brittle and ductile connections, respectively. A greater yield displacement, ultimate displacement, and forces were produced when these links were linked, increasing the ductility's ability to withstand an earthquake load (Diyana et al., 2022).

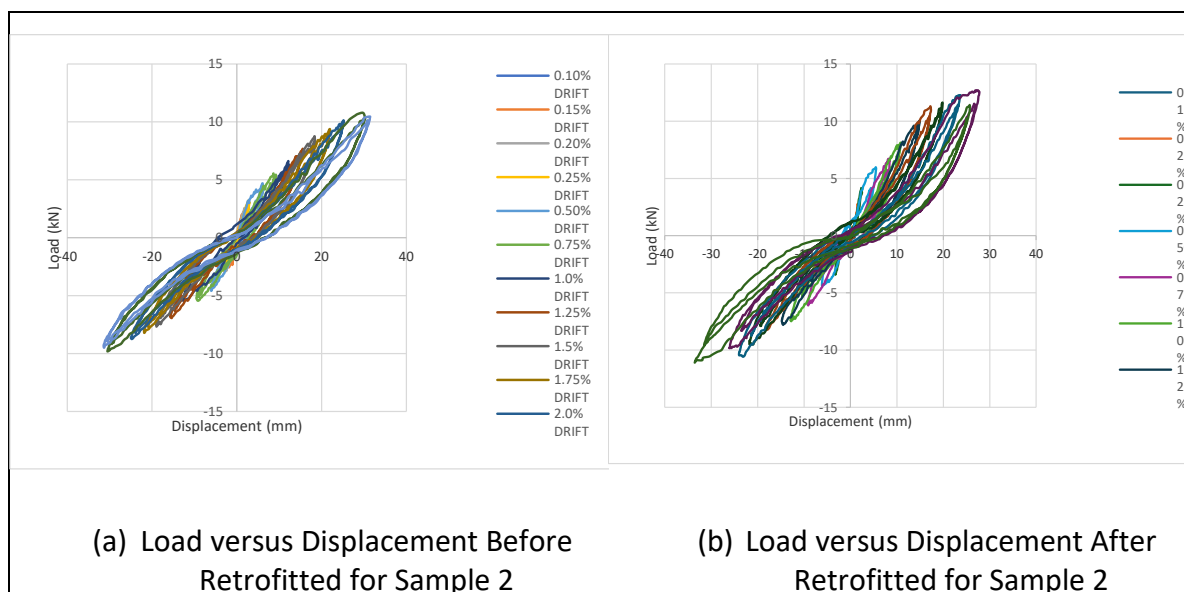

Figure 6. Load versus Displacement Before and After Retrofitting with R-ECC

Ductility

A study by (Maghsoudi & Akbarzadeh Bengar, 2006) found that the ductility of the beam-column joint is determined by comparing its behavior overall to the ultimate displacement to yield displacement ratio ($\mu = \Delta u / \Delta y$), yield rotation to ultimate rotation ratio ($\mu = \theta u / \theta y$), and amount of absorbed energy. These are the most used criteria. The comparison of maximum ductility and percentage difference for sample 2 before and after retrofitting

with R-ECC was shown in Table 1 and Table 2. Significant changes in ductility performance were demonstrated by comparing the maximum ductility with percentage differences for the beam-column joint under cyclic loading before and after retrofitting. The ductility value of the structure increased after retrofitted with R-ECC and permitting more deformation before failure. However, prior to R-ECC, structural design modifications that prioritised stiffness or load-carrying capacity resulted in a decrease in the ductility value. Based on curvature at the first yield and ultimate points, the ductility index is computed, which shows the member's capacity for energy absorption. Members with a higher ductility index gradually fail, revealing warning indications through fine cracks before complete collapse.

Table 1

Ductility (μ_{Δ}) of Beam-Column Joints Before Retrofitted

	Pushing Direction (Positive)		Pulling Direction (Negative)	
	1 st Cycle	2 nd Cycle	1 st Cycle	2 nd Cycle
Δ_u (mm)	29.77	30.88	30.52	30.59
Δ_y (mm)	21.7	22.1	23.4	-21.1
μ_{Δ}	1.37	1.40	1.30	1.45

Table 2

Ductility (μ_{Δ}) of Beam-Column Joints After Retrofitted

	Pushing Direction (Positive)		Pulling Direction (Negative)	
	1 st Cycle	2 nd Cycle	1 st Cycle	2 nd Cycle
Δ_u (mm)	27.58	26.66	26.14	23.44
Δ_y (mm)	18.2	17.8	16.2	17.9
μ_{Δ}	1.52	1.50	1.61	1.31

Equivalent Viscous Damping

According to Youssf et al (2015), viscosity damping can be experimentally determined using the logarithmic decrement method and the half power bandwidth method. The logarithmic decrement technique is used to calculate the damping characteristics of a structure from a free vibration test using time domain data. The amount of energy lost during a vibration cycle of the structure can be determined by computing the equivalent viscous system (Mohammadi, 2015).

The energy dissipation capacity and damping characteristics of sample 2 were enhanced by the retrofitting of R-ECC. Based on the equivalent viscous damping result shown in Table 3, Table 4, and Figure 7, the joint exhibited marginally less damping in the first cycle compared to the second, which means that it took in less energy during the initial shock prior to retrofitting. On the other hand, retrofitting resulted in consistently higher damping values for the second cycle than the first, suggesting better capacity for dissipating energy. An example of this improvement is provided by comparing the equivalent viscous damping values at drift levels before and after the retrofit. It is evident from these modifications that the retrofitting procedure enhanced the joint's energy dissipation capacity, a crucial factor in enhancing its seismic performance.

Table 3

Equivalent Viscous Damping of Beam-Column Joints Before Retrofitted

Drift (%)	Equivalent Viscous Damping, ξ_{eq} (%)	
	1 st Cycle	2 nd Cycle
2.25	6.90	3.85
2.5	1.67	4.89

Table Error! No text of specified style in document.

Equivalent Viscous Damping of Beam-Column Joints After Retrofitted

Drift (%)	Equivalent Viscous Damping, ζ_{eq} (%)	
	1 st Cycle	2 nd Cycle
2.25	6.96	4.33
2.5	12.14	16.03

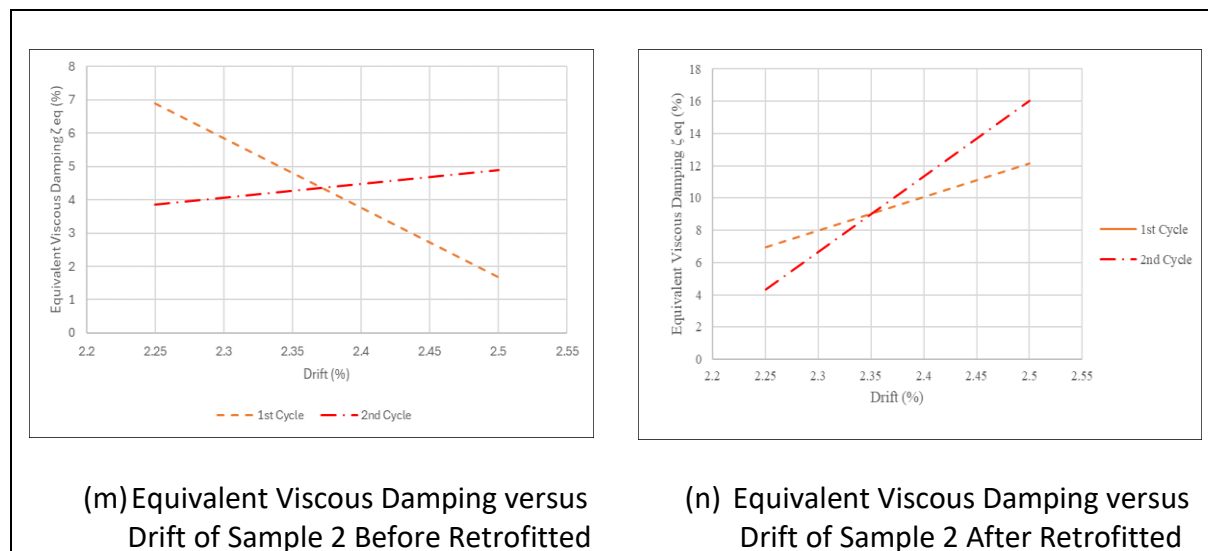

Figure 7. Equivalent Viscous Damping versus Drift of Sample 2 Before and After Retrofitted with R-ECC

Conclusion

In this study, the first objective was to determine the crack behavior of beam-column joints retrofitted with R-ECC jacketing subjected to lateral cyclic loading. The second objective of this study was to evaluate the load versus displacement of beam-column joints retrofitted with R-ECC jacketing subjected to lateral cyclic loading. The third objective was to analyse the ductility and equivalent viscous damping of beam-column joints retrofitted with R-ECC jacketing. Based on the result, load-displacement, ductility, and equivalent viscous damping of beam-column joints with crumb rubber were investigated.

- The study indicates that the use of R-ECC as a retrofit material may lead to the formation of cracks, altering their width and patterns.

- The load-displacement behavior of the retrofitted beam-column joints exhibited enhanced energy dissipation and increased resistance to crack initiation and propagation compared to the non-retrofitted beam-column joints.
- The beam-column joint strengthened with wire mesh and retrofitted with R-ECC improved deformation capacity and ductility, indicating enhanced energy dissipation capacity and seismic performance.

Acknowledgement

The authors would like to acknowledge Universiti Teknologi MARA (UiTM) Cawangan Pulau Pinang, Malaysia for supporting this research. The authors declare that they have no conflict of interest.

References

- Al-Fakih, A., Mohammed, B. S., & Liew, M. S. (2021). On rubberized engineered cementitious composites (R-ECC): A review of the constituent material. *Case Studies in Construction Materials*, 14. <https://doi.org/10.1016/j.cscm.2021.e00536>
- Alaloul, W. S., Musarat, M. A., A Tayeh, B., Sivalingam, S., Rosli, M. F. Bin, Haruna, S., & Khan, M. I. (2020). Mechanical and deformation properties of rubberized engineered cementitious composite (ECC). In *Case Studies in Construction Materials* (Vol. 13). Elsevier Ltd. <https://doi.org/10.1016/j.cscm.2020.e00385>
- Aziz, A. A., Rozli, M. I. F., Ghani, K. D. A., Jafri, N. A., & Zakaria, N. (2023). Effects of Pre-Treated Crumb Rubber as Sand Partial Replacement on Compressive Strength of Engineered Cementitious Composites (ECC). *Journal of Mechanical Engineering*, 20(2), 153–166. <https://doi.org/10.24191/jmeche.v20i2.22060>
- Diyana, N., Hayati, N., Hamid, A., Farhana, I., & Hassan, R. (n.d.). *Comparison of Seismic Response Corner Beam-Column Joint with and without Fuse Bars Under In-Plane Lateral Cyclic Loading*. 19(1), 1–22.
- Maghsoudi, A. A., & Akbarzadeh Bengar, H. (2006). Flexural ductility of HSC members. *Structural Engineering and Mechanics*, 24(2), 195–212. <https://doi.org/10.12989/sem.2006.24.2.195>
- Nagaraju, A., & Reddy Suda, V. B. (2022). An experimental study on R.C beam-column joints under cyclic loading. *Materials Today: Proceedings*, 52, 608–616. <https://doi.org/10.1016/j.matpr.2021.10.043>
- Youssf, O., Mills, J. E., & Hassanli, R. (2016). Assessment of the mechanical performance of crumb rubber concrete. *Construction and Building Materials*, 125, 175–183. <https://doi.org/10.1016/j.conbuildmat.2016.08.040>