

# Develop and Validate the Creativity Practice of Engineering Drawing Teachers (CPT-ED) Teaching and Learning Planning Framework

Suriana Ngatiman<sup>1</sup> Muhammad Sukri Saud<sup>2</sup>

Faculty of Educational Sciences and Technology, <sup>1&2</sup>Universiti Teknologi Malaysia, 81310  
Johor Bahru, Johor, Malaysia

Email: alsuriana782@yahoo.com & p-sukri@utm.my

**To Link this Article:** <http://dx.doi.org/10.6007/IJARBSS/v15-i1/24568>

DOI:10.6007/IJARBSS/v15-i1/24568

**Published Date:** 30 January 2025

## Abstract

Creativity in education plays an important role in fostering creative, critical thinking and innovation, especially for teachers in providing students with a more meaningful learning experience. In this regard, TL planning is the main building for teachers in practicing creativity to implement more organized and systematic teaching guided by the various needs of students and the subjects taught. This study aims to develop and validate the Engineering Drawing Teacher Creativity Practice (CPT-ED) Teaching and Learning Planning Framework. A mixed-methods approach is an option in the study design. Sequential Mixed Exploration Method to explore the constructs, sub-constructs and elements of the CPT-ED Teaching and Learning Planning Framework (TL) at the qualitative study phase stage. However, this study focuses on the quantitative phase of developing and validating the research framework by using two data analysis methods, namely Exploration Factor Analysis (EFA) and Validation Factor Analysis (CFA) which are analyzed using IBM-SPSS AMOS 23 software. The data was collected using a six-point Likert scale questionnaire from 300 teachers comprising ED teachers in nine SMTs across Malaysia and teachers teaching Technical Communication Graphics (TCG) subjects in Secondary Schools in Malaysia. This research highlights how TL Planning teachers' creative practices improve the effectiveness and smoothness of the overall teaching process and provide a meaningful experience to students. The findings of the study show that there are four sub-constructs and 15 TL elements of CPT-ED planning. The findings also show that the listed CPT-ED planning TL framework has met the characteristics of the appropriate model and has been validated. This study was conducted because of the importance of creativity in teaching as well as the need for guidance and reference for creative teaching practices, especially for the subject of Engineering Drawing (ED) referring to the research problems that have been identified.

**Keywords:** Develop, Validate, Creativity, Planning, Teaching, Learning, Framework

**Introduction**

Teachers' creativity cannot be taught, but applied indirectly through teaching activities by practicing creativity practices in a planned and orderly manner (Dagang, 2016; Sahrir et al., 2020). Based on a study conducted by Ahmad & Jingga (2015) and Brauer et al., (2024) There is a relationship between the level of teacher creativity and the practice of creativity in teacher teaching. Therefore, awareness of the potential of creativity and its practice is needed to increase the level of creativity of teachers to achieve learning objectives. An effective and quality lesson plan is the most important thing to transform education and increase student outcomes (Patfield et al., 2022; Hamdan et al., 2021). This statement is in line with the findings of the study Batjo & Ambotang (2019) It was found that there was a significant influence between the success of students and the quality of teachers' teaching. Moving on The quality of teachers' teaching is also influenced by teachers' creative practices in determining the success of a student (Batjo & Ambotang, 2019).

Engineering-related subjects require a creative teaching approach by teachers to ensure that students are guided to familiarize themselves with creative activities as well as the ability to analyze and evaluate problems related to engineering (Daly et al., 2014). Therefore, ED teachers need to have a clear understanding of creativity and especially in planning TL (Yasin et al., 2012; Ngatiman & Saud, 2022). Therefore, teachers should have the knowledge, understanding and skills to master creativity in teaching to enable the TL process to be carried out with enthusiasm, motivation and effectiveness (Seng & Othman, 2018).

However, there are challenges for ED teachers to practice creativity when planning and implementing TL due to the absence of specific guidance in accordance with the needs of ED subjects (Yasin et al., 2012; Ngatiman & Saud, 2022). In addition, there are also obstacles for ED teachers to plan TL creatively due to the need to complete the syllabus and a lot of subject content due to limited time (Ngatiman, 2018; Samsudin et al., 2013; Yasin et al., 2012). However, the problems that arise related to the lack of creativity of teachers in planning TL illustrate that the level of teachers' teaching creativity practices is still at a low level and requires attention (Corazza et al., 2021). In this regard, research related to the understanding and practice of teachers' creativity in planning TL requires full exploration to ensure the effectiveness of TL. Therefore, an CPT-ED framework for planning TL is developed based on the teaching needs of ED teachers and student learning.

**Literature Review***Sternberg's Theory of Creativity A Teacher's Guide to Practicing Creativity Planning TL*

This article examines teachers' creativity practices in planning TL. Sternberg's Theory of Creativity was chosen to underlie this study. This theory provides a structured perspective on how creativity can be nurtured and practiced, especially in teacher teaching. This study has placed six variables that are the conditions to enable an individual to be creative based on intelligence, knowledge, thinking style, personality, motivation and environmental conditions can form the construct, sub-construct and elements of teacher teaching creativity practice. It is hoped that the variables listed can complement and refine the theoretical framework of this study and subsequently be able to develop a comprehensive CPT-ED Planning TL Framework that can be used as a guide for teachers to practice creativity in their teaching. In the context of the practice of teacher teaching creativity based on Sternberg's Creativity Theory, it shows the important role of teachers in nurturing and developing

creativity in them. Among the important points that have been identified based on this theory are variables that can arouse teachers' intelligence, encourage creative thinking styles, foster openness and courage, increase motivation and create an appropriate learning environment (Gralewski & Karwowski, 2018).

Sternberg's theory of creativity is also a guide for teachers to understand and increase motivation to practice creativity in teaching. In addition, teachers need to always be motivated to set goals clearly in their teaching. In addition, the determination and establishment of a conducive learning environment is an important factor in encouraging teachers' creativity. Teachers need to ensure that a comfortable learning environment is needed to generate creative thinking including reducing barriers such as strict rules or bureaucratic regulations that can hinder creativity in the TL process (Brouwers & Vijver, 2015). In this regard, the role of teachers in adapting creative elements such as synthetic activities, practical projects, and assessments that encourage variety and problem-solving is very important in lesson planning (Rushdi & Amran, 2020). Therefore, the practice of teachers' creativity when planning TL by involving in-depth knowledge of the subject and pedagogical skills can also promote innovative learning. Furthermore, the selection of this theory can also be used as a guide for teachers to understand and carry out their roles crucial They in forming a learning environment that focuses on the development of their own creativity and even students.

#### *The Importance of Teacher Creativity Practices in Planning Teaching and Learning*

Lesson planning is a comprehensive preparation for successful teaching and a well-structured lesson plan maximizes students' achievement in teaching delivery (Alfiani & Nurcholis, 2023). While Yonkaitis (2020) He also added that the lesson plan serves as a guide to help teaching be more focused and organized. Learning planning refers to the strategies and steps taken by teachers and students to achieve the expected learning outcomes. Ramadani & Sutriani (2023) and Muis et al., (2015) It was also stated that the learning plan illustrates a systematic strategy and plan that involves students in the effective learning process. In the context of this study, the practice of creativity in planning TL refers to the creativity of teachers using a comprehensive approach to integrate knowledge, lesson development and learning methods in a structured manner. In addition, the practice of creativity in designing TL is to show how teachers plan a fun learning atmosphere, organize teaching objectives, adjust TL plans based on the needs of each student, choose TL strategies that can provide opportunities for students to explore their learning and then determine the use of resources and Teaching Aids (TA) that can help achieve educational goals.

Basically, teachers' creativity in creatively designing TL is one of the main constructs needed by teachers in ensuring the effectiveness of teaching and learning (Awi & Zulkifli, 2021; Mohd Nor et al., 2020; Mohd Taib & Mustapha, 2017). In this regard, teachers' creativity in planning TL in an orderly manner by paying attention to the objectives and needs of the subjects as well as taking into account the needs of students should be given proper attention by teachers. In this context, planning an organized TL can not only increase the effectiveness of the learning process but also strengthen students' understanding and prepare them with the necessary skills and knowledge. Therefore, in line with the need to ensure the effectiveness of teaching in accordance with the requirements of the Effective Teaching Framework Model, teachers who practice creativity when planning TL tend to improve the

quality of their teaching. Therefore, teachers' efforts to utilize various creative strategies and methods are also taken into account to ensure the effectiveness of their teaching delivery.

In addition, the practice of teachers' creativity in planning TL is also the most important aspect in facing contemporary education, thus preparing students to face challenges and opportunities in the era of globalization and industrial revolution 4.0. Therefore, teachers' efforts to practice creativity when planning TL using a systematic approach and careful consideration are needed to ensure that the lesson plan can provide a meaningful and effective learning experience for all students (Mohd Mustafa, 2017). The determination of specific teaching and learning objectives at the initial stage during lesson planning is aimed at ensuring that teachers' teaching becomes more directed and can stimulate interest and enable students to play an active role throughout the learning process. By considering the knowledge and skills possessed by students as well as the needs of the lesson content, the planned teaching objectives become more realistic (The Murtiyasa, 2023; Wang, 2022). Meanwhile, the emphasis on the importance of dividing teaching objectives into different levels can also integrate content knowledge, teaching materials and active learning can produce realistic teaching objectives in line with students' knowledge and skills (Richards, 2010; Pasiangan et al., 2020).

Therefore, the development of teaching objectives must also be able to evaluate the effectiveness of teachers' teaching (Broadfoot, 1988; Mohammed & Karim, 2023). In this regard, teaching objectives that can evaluate teachers' teaching performance are very meaningful and valuable (Sidek et al., 2020; Kit & Mahmud, 2023) as well as being able to evaluate the quality of delivery for future teaching improvement (Amran et al., 2022). In an effort to plan teaching objectives by applying creative TL activities, it can provide an overview of effective pedagogical strategies and have a significant impact on student engagement and performance (Sariffuddin & Ahmad, 2023). Therefore, these findings also show that, when planning teaching objectives, teachers should have good knowledge and competence in the subjects taught as well as have skills in pedagogy and various creative TL methods and strategies in accordance with the content of the subjects.

Teachers' creativity in adapting students' backgrounds when planning TL is important in ensuring the effectiveness of teachers' teaching, which in turn can adapt to the diversity of students' thinking styles and abilities (Kaviza & Ibrahim, 2022). In addition, teachers' efforts to understand the diverse backgrounds of students can influence teaching approaches as well as the construction of a more conducive learning environment (Hartini et al., 2020; Marimuthu & Malayalam, 2020). The focus on students' needs can also highlight the creativity and innovation of teachers when planning lessons (Gunawan et al., 2020; Sari, 2019). Taking into account the students' existing experience, it helps to facilitate the TL process and consideration should be given so that the lesson plan prepared is suitable for the existing knowledge and subject requirements (Maba & Mantra, 2018; Alanazi, 2019) In turn, making learning more meaningful and valuable for students (Namdar & Kucuk, 2018).

Next, the teacher's creative practice in formulating teaching strategies that will be used throughout the TL process must be adjusted according to the requirements of the title and content of the subjects taught (Mustaffa et al., 2021a; Sariffuddin & Ahmad, 2023). Meanwhile, efforts to use appropriate teaching strategies such as student-centred strategies

can also foster students' creativity by focusing on the use of various teaching strategies, methods and techniques that are suitable for the diversity of students (Sarifuddin & Ahmad, 2023). In addition, through the use of models Flipped Classroom is also a student-centered teaching that needs to be expanded in tandem with current education (Kaviza, 2019). Therefore, the courage of teachers to choose the latest teaching strategies is seen to increase the active participation of students and reflect the diversity of students. In addition, the use of appropriate teaching strategies also supports the idea that creative teachers play an important role in motivating students to be active and form engaging learning experiences (Irfani, 2022).

Teachers who practice creativity can form systematic lesson plans, establish the use of TA, and choose effective teaching strategies (Setiawan et al., 2019). Along with the development of the field of educational technology, the use of technology in teaching includes the use of digital drawing software (such as Computer-Aided Design, 3D, 5D modeling tools Planner, Google Sketchup) is an important point in planning the use of TA in accordance with the topic being taught. In addition, teachers' creativity in selecting and determining the use of Information Communication Technology (ICT) can facilitate teaching and change daily teaching practices to be more attractive (Nurhayani et al., 2020; Wirawan et al., 2020; Mesran et al., 2021). Meanwhile, the flexibility of teachers to access information in an orderly and integrated manner by integrating technology in their pedagogy makes teaching more structured and effective (Mishra & Koehler 2006; Akram et al., 2022; Mariscal et al., 2023). In addition, the need for innovating the existing TA based on the needs of the lesson content should also be taken into account when planning the TL. The need for teachers to plan to innovate the existing TA based on the content of instruction and the current needs of students is very welcome (Gunawan et al., 2020; Duda et al., 2018). Through the creation and development of innovative TA, it can also highlight the integration of teachers' creativity that is structured and thoughtful in practicing creativity in teaching (Hidayat et al., 2023).

### *Study Aims*

This study aims to develop and validate the CPT-ED Teaching and Learning Planning Framework

### **Study Methodology**

This study aims to develop and validate the CPT-ED TL Planning Framework. To complete this study, a combined approach (Mixed Methods) as an option in the design of the study conducted. Sequential exploration combined method (Exploratory Sequential Mixed Method) to explore the constructs, sub-constructs and elements of the CPT-ED TL Planning Framework at the qualitative study phase stage. However, this study only focuses on the quantitative phase of developing and validating the study framework. To complete the study, a questionnaire using a 6-point Likert scale was used. Selection of methods using links google form through the giving link The questionnaire was also chosen because it is very suitable for limited movement and takes into account the security situation and the ability to access the form at any time with the help of the internet as recommended by Fricker (2012). For the purpose of quantitative data collection, the population of this study consists of all ED teachers in nine SMTs throughout Malaysia and teachers who teach the subject of Technical Communication Graphics (TCG) in Secondary School Day in Malaysia. For the purpose of the study sample selection process, the staged sampling technique (Multistage Sampling) was

used for the purpose of completing the sampling process of this study. In accordance with the recommendations Etikan & Bala (2017), the staged sampling technique combines several techniques for effective and efficient sampling. The choice of this technique is because it involves a relatively large population covering a large geographical area (Ethics & Bala, 2017; Neuman, 2011). In this regard, the selection of this multi-sampling technique, using the cluster sampling technique (cluster sampling) and breaking down the study population into several groups or zones taken into account to conduct over a large geographical area. The total number of respondents involved in meeting the sample requirements for this study was 300 people. The researcher used two data analysis methods to complete the purpose of the study, namely the Exploration Factor Analysis (EFA) method and the Validation Factor Analysis (CFA) method which were analyzed using IBM-SPSS AMOS 23 software.

## Findings and Discussion

### *Exploration Factor Analysis (EFA) Analysis Findings*

To develop the CPT-ED TL Planning framework, the researchers used the EFA analysis method to group the elements in one sub-construct. Accordingly, an EFA analysis was conducted referring to each sub-construct element contained in the constructed framework. There are four sub-constructs contained in the TL Planning construct, namely the sub-construct of setting teaching objectives (AA), adapting the background of students (AB), developing teaching strategies (AC) and determining the use of Teaching Aids (AD). Accordingly, the results of the analysis of the four factors involved were collected and elaborated in one table. The summary of the KMO Schedule and Bartlett's Test of Sphericity for each sub-construct contained in the construct of teacher creativity practice Planning TL is shown in Table 1. Referring to the results of the exploration factor analysis, it was found that the KMO value for the four sub-constructs of the TL planning teacher's creativity practice was above 0.6 which ranged from 0.605 to 0.691. While the Bartlett's Test values for the AA, AB, AC and AD constructs (Chi-Square = 68.010, 83.276, 82.325 and 47.954) and p-values = 0.000 for all the sub-constructs. These findings show the adequacy of sampling to conduct factor analysis on all sub-constructs of designing TL.

Table 1

### *KMO Schedule and Bartlett's Test for TL Planning Constructs*

KMO and Bartlett's Test		AA	OFF	AC	AD
Kaiser-Meyer-Olkin Measure of Sampling Adequacy.		0.691	0.605	0.650	0.642
Bartlett's Test of Sphericity	Approx. Chi-Square	68.01	83.276	82.325	47.954
	Dif	10	10	10	10
	Mr.	0.000	0.000	0.000	0.000

Meanwhile, Table 2 shows the matrix components that combine the four sub-constructs of Planning TL, and it is found that all elements from AA1 to AA5 have a factor weighting range ranging from 0.652 to 0.790. While elements AB1 to AB5 have a factor-weighting range of 0.645 to 0.712, elements AC1 to AC5 have a factor-weighting range of 0.686 to 0.837 and elements AD1 to AD5 have a factor-weighting range of 0.648 to 0.768. All weighting ranges achieved by all elements contained in the TL Planning construct are above 0.6 values.

Table 2

*Components and Weighting values for TL Planning Sub-Constructs*

	AA Component	AB Component	AC Component	AD Component
AA1	.689			
AA2	.790			
AA3	.743			
AA4	.760			
AA5	.652			
AB1		.689		
AB2		.790		
AB3		.743		
AB4		.760		
AB5		.650		
AC1			.702	
AC2			.760	
AC3			.712	
AC4			.692	
AC5			.645	
AD1				.667
AD2				.710
AD3				.768
AD4				.648
AD5				.733

These findings also show that all the elements listed can well describe the entire sub-construct contained in the TL planning construct.

*Factor Validation Analysis (CFA) Analysis Findings*

Factor Validation Analysis (CFA) is carried out to test the validity of the elements that are indicators to measure the sub-constructs and constructs of Designing TL. Accordingly, the Measurement Model Analysis of the creative practice of teachers in Designing TL is explained one by one based on the sub-constructs and elements that have been listed. CFA analysis for each sub-construct element is carried out to ensure that the model matches the study data. There are four sub-constructs contained in the teacher's creativity practice construct Planning TL, namely, setting teaching objectives (AA), adapting students' backgrounds (AB), developing teaching strategies (AC) and determining the use of TA (AD). An explanation of the findings of the Measurement Model Analysis for each sub-construct is presented in the subheading below.

*(a) Sub-Construct Measurement Model Sets Teaching Objectives (AA)*

Figure 1 shows the initial measurement model of the sub-construct of Setting Teaching Objectives which consists of five elements, namely planning specific teaching objectives (**AA1**); planning teaching objectives realistically (**AA2**); taking into account students' abilities (**AA3**); adapting teaching to the content of ED subjects (**AA4**) and measuring teacher delivery performance (**AA5**). Analysis of the initial measurement model shows a rather weak fit model. The findings also showed that all elements achieved a factor weighting value of more than 0.6. However, it was found that the fitness indexes still did not reach the minimum values (RMSEA= 0.213 and Chisq/df = 6.102). Accordingly, with reference to the modification Indices, the modification of the AA2 and AA3 element pairs has a high measurement error value of

30.314. Therefore, the AA3 element was dropped because it had the lowest factor loading and the CFA analysis was re-conducted.

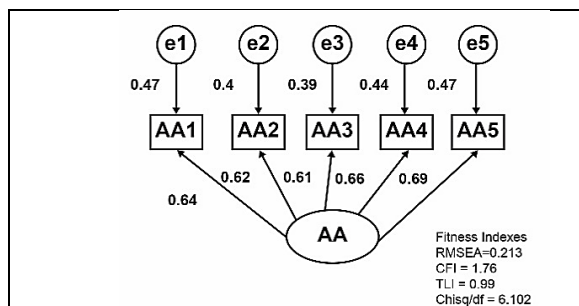

Figure 1 Initial Measurement Model Sub Construct Establishes Teaching Objectives.

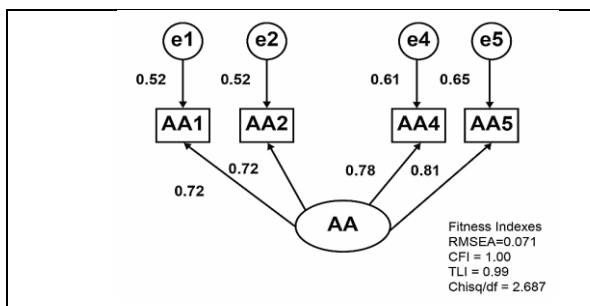

Figure 2 The final measurement model of the sub-construct establishes the teaching objectives.

Figure 2 shows that the CFA analysis was re-conducted after removing the AA3 element. It was found that this final measurement model had been able to meet the set criteria and showed that the fitness indexes had reached the minimum values of RMSEA= 0.074 (<0.08) and CFI = 1.00 (>0.9), TLI = 0.99 (>0.9) and Chisq/df = 2.687 (<3.0). Furthermore, the validity and reliability analysis for the sub-construct of Designing Teaching Objectives shows that the validity of convergence through the AVE value is 0.531 (>0.50) and the composite reliability through the C.R value is 0.713 (>0.6). Accordingly, the measurement model of the Establishing Teaching Objectives sub-construct shows good validity and reliability.

(b) *Measurement Model Sub Construct Adjusting Student Background (AB)*

Figure 3 shows the initial measurement model of the sub-construct of Adapting Pupil Background which consists of five elements, namely teacher's creativity focusing on students' needs (**AB1**); relating to students' existing experiences (**AB2**); taking into account students' diversity (**AB3**); anticipating pupil involvement (**AB4**) and adapting assessments to students' levels (**AB5**). Analysis of the initial measurement model shows a rather weak fit model. The findings also showed that four elements showed a factor weighting of more than 0.6, but the AB3 element showed a factor weighting of 0.58 which was less than 0.6 and should be noted to be removed. The researchers also found that the fitness indexes still did not reach the minimum values set, namely RMSEA= 0.118 which is above 0.08 and Chisq/df = 5.823 (>3.0). Accordingly, with reference to the modification Indices, the modification was made on the AB1 and AB4 element pairs which have a high measurement error value of 26.452. As such, the AB4 element was dropped as it had the lowest factor loading and the CFA analysis was re-conducted. Therefore, there are two elements that were omitted, namely AB3 and AB4 elements for the purpose of fulfilling the requirements in performing the measurement model analysis.



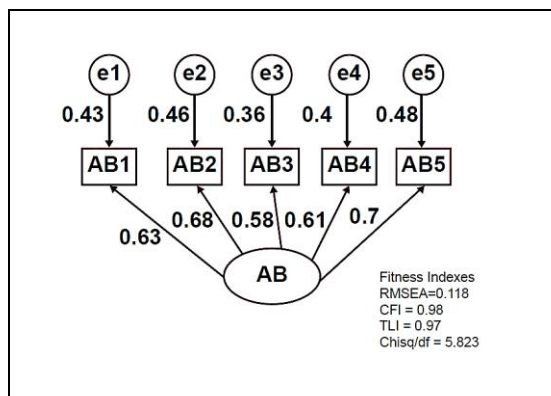

Figure 3 Subconstruct Initial Measurement Model Adjusting the Student's Background

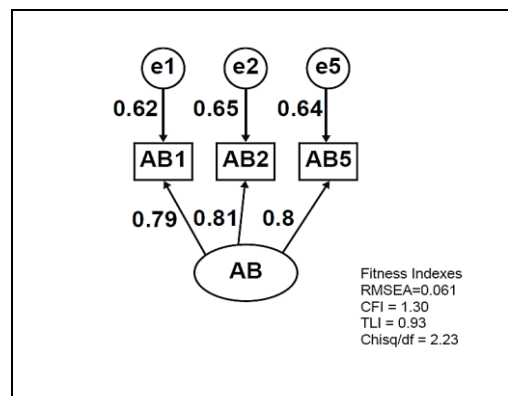

Figure 4 Sub-construct Final Measurement Model Adjusting the background of the pupils

Referring to Figure 4, the CFA analysis was re-run after removing the AB3 and AB4 elements. The researchers found that the final measurement model had met the set criteria and showed that the fitness indexes reached the minimum values of RMSEA= 0.061 (<0.08) and CFI = 1.30 (>0.9), TLI= 0.93 (>0.9) and Chisq/df = 2.23 (<3.0). Furthermore, the analysis of the validity and reliability of the sub-construct of the teacher's creativity practice adjusted the background of the pupils showed that the convergent validity through the AVE value was 0.61 (>0.50) and the composite reliability through the C.R value was 0.68 (>0.6). In this regard, the model of measuring teachers' creativity practices adapting to students' backgrounds shows good validity and reliability.

(c) *Measurement Model Sub - construct Developing Teaching Strategy (AC)*

Figure 5 shows the initial measurement model of the sub-construct of Developing Teaching Strategies which consists of five elements, namely diversifying student-centered activities (**AC1**); encouraging creative activities (**AC2**); applying innovative teaching strategies (**AC3**); encouraging students to play an active role (**AC4**) and adapting teaching strategies to creative activities (**AC5**). Analysis of the initial measurement model shows a rather weak fit model. The results showed that all elements showed a factor weighting factor of more than 0.6. However, it was found that the fitness indexes still did not reach the minimum value because the value of RMSEA= 0.128 was above 0.08 and Chisq/df = 4.21 (>3.0). Accordingly, by referring to the modification Indices, the researcher took steps to modify the element pairs with high measurement error values of AC1 and AC2 which are 57.123 and the element pairs AC3 and AC4 which have measurement error values 29.612. Accordingly, the researcher took action to remove the AC2 and AC4 elements as they recorded the lowest weighting factor values and the CFA analysis was re-conducted.

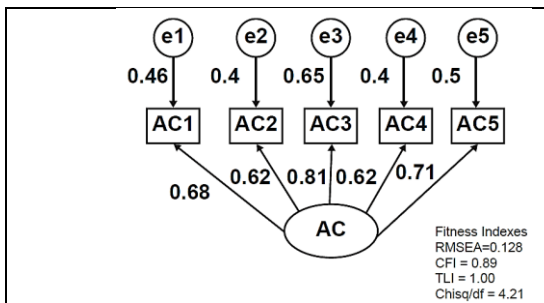

Figure 5 Sub-construct Initial Measurement Model Developing Teaching Strategies

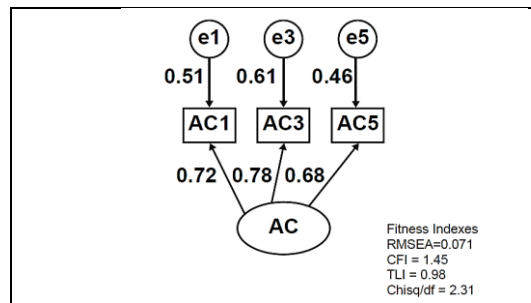

Figure 6 Sub-construct Final Measurement Model Developing Teaching Strategies

Referring to Figure 6, the CFA analysis was re-run after performing the aborting of AC2 and AC4 elements. The researchers found that this final measurement model had been able to meet the set criteria and showed that the fitness indexes had reached the values of RMSEA= 0.071 (<0.08) and CFI = 1.45(>0.9), TLI= 0.98 (>0.9) and Chisq/df = 2.31 (<3.0). Furthermore, the findings of the analysis of the validity and reliability of the sub-construct of teachers' creativity practices in Developing Teaching Strategies also showed that the validity of convergence through the AVE value was 0.61 (>0.50) and the composite reliability through the C.R value was 0.76 (>0.6). In this regard, the measurement model of the sub-construct of teachers' creativity practices in Developing Teaching Strategies shows good validity and reliability.

(d) *Sub-Construct Measurement Model Determines the Use of TA (AD)*

Figure 7 shows the initial measurement model of the sub-construct of teachers' creativity practices Determining the use of TA which consists of five elements, namely teachers' creativity in applying technology in teaching (**AD1**); creating creative TA (**AD2**); Using TA in real form (**AD3**); diversifying the use of TA to facilitate the delivery process (**AD4**) and innovating existing TA(**AD5**). Analysis of the initial measurement model shows a rather weak fit model. The findings showed that all elements achieved a factor weighting factor of more than 0.6. However, it was found that the fitness indexes still did not reach the minimum value because the value of RMSEA= 0.092 which is above 0.08 and Chisq/df = 4.531 (>3.0). Accordingly, by referring to the modification Indices, the researcher took steps to constrain the pairs of elements that showed high measurement error values, namely e3 and e4 and e4 and e5. The CFA analysis is re-run after the constraints have been applied.

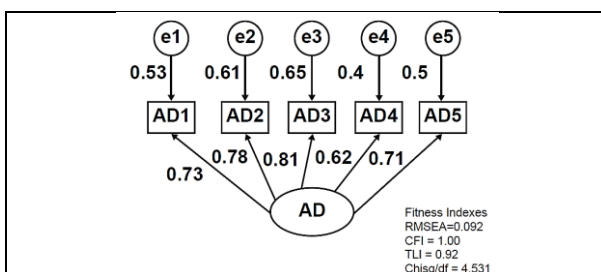

Figure 7 Sub-construct Initial Measurement Model Determines the Use of TA

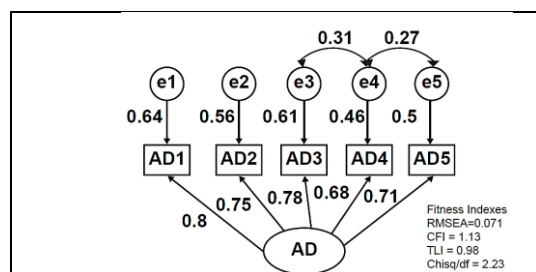

Figure 8 Sub construction Final Measurement Model Determines TA Usage

Referring to Figure 8, the CFA analysis is rerun after performing constraints. The researchers found that this final measurement model had been able to meet the set criteria and showed that the fitness indexes had reached a minimum value of RMSEA= 0.071 (<0.08) and CFI = 1.13 (>0.9), TLI= 0.98 (>0.9) and Chisq/df = 2.23 (<3.0). Furthermore, the analysis of the validity and reliability of the sub-construct of teacher creativity practice determined that the use of TA showed that the validity of convergence through the AVE value was 0.692 (>0.50) and the composite reliability through the C.R value was 0.890 (>0.6). In this regard, the measurement model of the sub-construct of teacher creativity practice Determining the Use of TA shows good validity and reliability.

After conducting a CFA analysis of the measurement model for each sub-construct contained in the teacher creativity practice construct teacher creativity practice planning TL, the process of evaluating the measurement model from the aspect of validity and reliability of a measurement model continues. Therefore, the researcher conducts combined measurements simultaneously for each measurement model by evaluating the unidimensionality, validity and reliability of each construct carried out. The findings of the pooled-CFA procedure for the overall construct of teacher creativity practice Planning TL are shown in Figure 9.

Figure 9 also shows that the correlation value of the combination of sub-constructs that form the construction of the teacher's creativity practice Planning TL has a good correlation of less than 0.85. In this regard, no multicollinearity problem was identified for the construction of teachers' creativity practices in Planning TL.

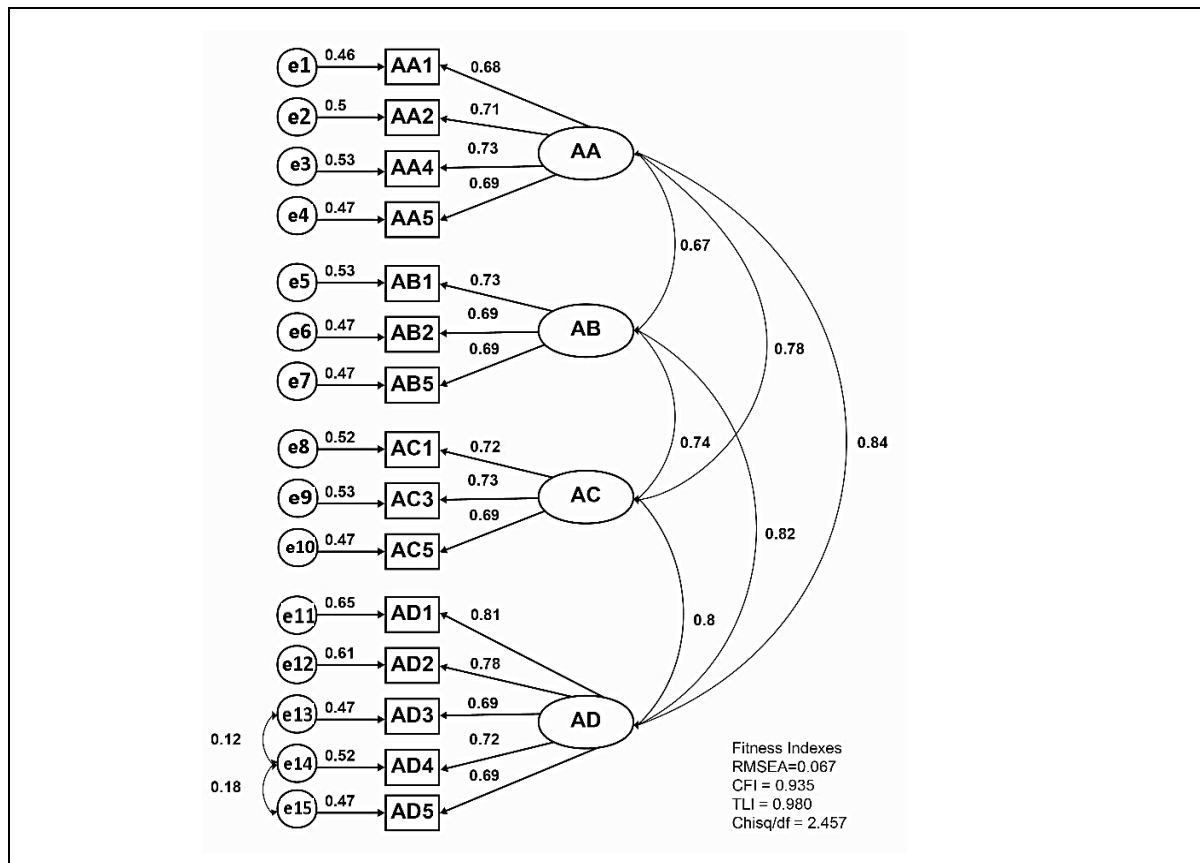

Figure 9 Analysis of Pooled CFA Construct Creativity of Teachers Designing TL

After the calculation of AVE and CR values is carried out, an assessment of the normality of the data distribution is carried out to ensure that the data collected are scattered normally. The results of the normality test showed that the skewness value was in the range of -1.5 to +1.5. Meanwhile, the kurtosis value is between -7.9 to +7.0.

The findings also show that the data obtained are scattered normally and are suitable for SEM analysis. After the validity, reliability and normality tests were carried out, the next analysis was to concentrate on Maximum Likelihood Estimates Regression weight, Squared Multiple Correlation analysis, model fit analysis, covariance and correlation analysis were conducted. The findings of the study showed that the Critical Ratio (CR) values for all indicator elements ranged from -1.96 to +1.96. Accordingly, this study shows that all the elements of the indicator are significant to the study construct. Furthermore, the standardized regression weight showed that all elements of the indicator recorded values between 0.673 and 0.846. The regression values obtained show that all indicators can significantly represent the constructs contained in the CPT-ED Framework. This study also found that all Squared Multiple Correlation (SMC) values for the elements of the CPT-ED TL Planning Framework exceeded 0.3 values, indicating that all these elements could measure the sub-constructs and constructs of CPT-ED.

To complete this study, the findings of the model matching analysis were also carried out and shown in Table 2. The model fit test includes the Goodness of fit Square Test, Baseline Comparison and RMSEA values are referenced to ensure that the model fit is in line with the study data obtained. The Baseline Comparison value should be above 0.90, while the RMSEA value should be less than 0.08 and prove that the proposed framework model is significant with the study data.

Table 3

*Fit Summary Framework for Teaching Creativity Practice for ED Teachers*

Model	NF		R		IFI		T		CF		RM
	I Delta 1	FI rho1	Delta2	FI rho2	I	SEA					
Default Model	45	.8	53	.8	67	.9	54	.9	78	8	0.06
Saturated model	000	1.	000	1.	000	1.	000	1.	000	000	1.
Independence Model	00	0.	00	0.	00	0.	00	0.	00	00	0.

Table 3 also shows that the NFI (Normal Fixed Index), RFI (Relative Fix Index) values obtained show that the values obtained are less than 0.9 while IFI (Incremental fit), TFI (Tucker-Lewis Fix Index) and CFI (Compare Fix Index) reach values above 0.90. Next, the RMSEA (Root Mean Square Error of Approximation) value obtained is 0.068 which is less than 0.08. These findings also confirm that the skeletal model constructed is significantly consistent with the study data.

Overall, it can be concluded that the CPT-ED TL Planning Framework developed has met the characteristics of good model fit and has been verified. Therefore, the TL Planning teacher creativity practice framework can officially be adopted by all ED teachers as a reference for practicing creativity in teaching. A summary of the final framework based on the EFA and CFA analyses is shown in Table 4.

Table 4

Details of CPT-ED, TL Planning Framework

CONST RUCT	SUB CONSTRUCT	ELEMENT
PLANNING TL	Set Teaching Objectives	1. Designing specifically.
		2. Plan realistically.
		3. Adapting teaching to the content of the subject.
		4. Measuring teacher delivery performance.
	Adjusting to Background pupil	1. Focus on the needs of students.
		2. Relate to students' existing experiences.
		3. Adjusting the assessment to the level of the student.
	Pile up Teaching Strategies	1. Diversify student-centered activities.
		2. Applying innovative teaching strategies.
		3. Adapting teaching strategies to creative activities.
	Determine Uses of TA	1. Applying the use of technology in teaching.
		2. Create creative TA.
		3. Using Teaching Aid in real form.
		4. Innovating existing Teaching Aid.
		5. Diversify the use of Teaching Aid

The data analysis process of this study involves the procedure of grouping elements in one sub-construct to ensure the adequacy of sampling using EFA analysis. Furthermore, the proposed framework of the CPT-ED obtained has been validated using the CFA analysis method. Validity and reliability through SEM analysis have found that four sub-constructs and consisting of 15 elements in the developed TL Planning construct have met the characteristics of good model fit to form the CPT-ED TL Planning framework.

**Discussion**

The validation factor analysis was carried out to prove that the constructs, sub-constructs and elements obtained from the findings of the qualitative study were valid and reliable. There are two types of analyses that have been carried out to ensure the matching of measurement models based on the findings of the study. For the first analysis, the measurement model for each sub-construct and frame element of the CPT-ED Designing TL was carried out CFA analysis. At this stage, only measurement models that achieve the specified matching index are accepted. The reference used to achieve this purpose is to refer to elements or items that have a weighting factor of less than 0.6 dropped. Meanwhile, the convergent validity and composite reliability of each element are also referenced and ensured to reach the minimum values set as proposed by Awang (2015) and Hair et al., (2014)

In the first stage, CFA analysis has been carried out on the elements contained in each sub-construct that represents the CPT-ED Designing TL construct. Next, the analysis of the validation factor involving the combination of all elements for each sub-construct is carried

out in a Pooled-CFA manner to ensure that there is no multicollinearity problem based on the correlation value obtained at the initial stage before proceeding to the next stage. Next, the analysis of the verification factor analysis by involving the combination of all sub-constructs for each construct was carried out in a Pooled-CFA manner again to determine the correlation value between the sub-constructs to ensure that there is no multicollinearity problem. The findings show that the CPT-ED Planning TL construct listed has met the characteristics of a good model fit and has been validated.

In this regard, the CPT-ED Planning TL framework consists of 4 sub-constructs and 15 elements. The overall findings from the CFA process have eliminated 5 elements in the initial framework of the CPT-ED by taking into account the failure factors of compliance with the model fit characteristics and the development of the framework. However, overall, the CPT-ED framework developed was found to still meet the characteristics of the model fit based on the CFI, NFI, TLI value index which also achieved a good fit value and could be confirmed.

In this regard, these findings can be used as a guide for ED teachers to practice creativity in TL Planning, namely by setting specific and realistic teaching objectives while adapting teaching to the content of the subject as well as being able to measure the performance of teacher delivery. This is in line with the study by Awi & Zulkifli (2021) and Mohd Nor et al., (2020) which emphasized the importance of teachers' creativity in structuring lesson plans in accordance with the needs of the subject and even measuring the effectiveness of teachers' teaching. ED teachers also need to tailor the lesson plan based on the student's background, among others, by focusing on the needs and linking existing experience and planning assessments based on the student's level. These findings align with the creativity component of synthetic and analytical intelligence as suggested by Sternberg, where teachers integrate knowledge, adapt strategies, and critically evaluate its effectiveness to meet the needs of diverse pupils. In addition, teachers' creativity in formulating teaching and assessment strategies must diversify student-centered creative activities as well as apply innovative teaching strategies in their teaching. In addition, teachers' creativity practices in planning the use of TA also require teachers to diversify, create and innovate existing TA and use TA in the form of *maujud* to facilitate delivery.

### **Conclusion and Recommendations**

In conclusion, these findings provide valuable insights with the adaptation of Sternberg's theory of creativity as the main backdrop to the development of the Framework that forms an CPT-ED Planning TL. In line with these findings, Sternberg's theory of creativity practice clearly shows that creativity in teacher teaching is not a solitary trait but a multifaceted process formed as a result of the interaction of cognitive, emotional and contextual factors towards the effectiveness of the learning process. The implications of these findings show that the focus on teachers' ability to think flexibly, priorities emotional intelligence, understand and appreciate the factors or situations that occur around them can create a supportive environment and foster creativity ultimately contributing to more effective and innovative teaching. This study can also have significant implications for ED teachers in SMT who also play an important role in ensuring the success of students. Through the practice of teachers' teaching creativity, Planning TL enables the implementation of TL to be more effective and provides a more meaningful learning experience to students. Therefore, it is proposed that other further studies related to teachers' creative teaching

practices to develop students' creativity can also be carried out as a reciprocity to identify the constructs, sub-constructs and elements of teachers' teaching practices towards students' creative learning.

## References

- Abu, N. E., & Eu, L. K. (2014). Hubungan Antara Sikap, minat, pengajaran guru dan pengaruh rakan sebaya terhadap pencapaian matematik tambahan Tingkatan 4. *Jurnal Kurikulum & Pengajaran Asia Pasifik*, 2(1), 1–10. <https://doi.org/10.1140/epjc/s10052-012-2241-5>
- Ahmad, A., & Jingga, N. (2015). Pengaruh kompetensi kemahiran guru dalam pengajaran terhadap pencapaian akademik pelajar dalam mata pelajaran Sejarah. *Jurnal Kurikulum & Pengajaran Asia Pasifik*, 3(2), 1–11.
- Alanazi, M. H. (2019). A Study of the Pre-Service Trainee Teachers Problems in Designing Lesson Plans. *Arab World English Journal*, 10(1), 166–182. <https://doi.org/10.24093/awej/vol10no1.15>
- Alfiani, S., & Nurcholis, I. A. (2023). Strategies for Designing Effective Lesson Plan in Micro Teaching Practices Perceived by Indonesian EFL Student Teachers. *English Learning Innovation*, 4(1), 58–67. <https://doi.org/10.22219/englie.v4i1.17647>
- Amran, N. F. N., Hashim, N. F., Jumadi, M. K. N., Mohamad Jamil, N., Ibrahim, N., Sagin, C., & Husin, M. R. (2022). Pengurusan Alam Pembelajaran di Sekolah Kebangsaan Nanga Temalat Sarawak. *Journal of Humanities and Social Sciences*, 4(2), 64–72. <https://doi.org/10.36079/lamintang.jhass-0402.388>
- Awang, Z. (2015). *SEM Made Simple: A Gentle Approach Structural Equation Modeling*. MPWS Rich Publication.
- Awi, N. A. L., & Zulkifli, H. (2021). Amalan kreativiti guru pendidikan islam dalam pembelajaran abad ke-21. *ASEAN Comparative Education Research Journal on Islam and Civilization (ACER-J)*, 4(1), 40–54.
- Batjo, N., & Ambotang, A. S. (2019). Pengaruh Pengajaran Guru Terhadap Kualiti Pengajaran Guru. *Malaysian Journal of Social Sciences and Humanities (MJSSH)*, 4(2), 30–42.
- Brauer, R., Ormiston, J., & Beausaert, S. (2024). Creativity-Fostering Teacher Behaviors in Higher Education: A Transdisciplinary Systematic Literature Review. *Review of Educational Research*, 0(0), 1–30. <https://doi.org/10.3102/00346543241258226>
- Broadfoot, P. (1988). Assessing teacher performance. *Journal of Education Policy*, 3(1), 39–50. <https://doi.org/https://doi.org/10.1080/0268093880030104>
- Brouwers, S., & Vijver, F. J. (2015). Contextualizing intelligence in assessment: the next step. Human. *Human Resource Management Review*, 25(1), 38–46. <https://doi.org/doi.org/10.1016/j.hrmmr.2014.09.006>
- Corazza, G. E., Reiter-Palmon, R., Beghetto, R. A., & Lubart, T. (2021). Intelligence and creativity in the space-time continuum for education, business, and development. *Journal of Creativity*, 31, 1–6. <https://doi.org/10.1016/j.yjoc.2021.100003>
- Dagang, M. Y. (2016). *Amalan Kreativiti Pengajaran Guru Pendidikan Islam Di Sekolah Negeri Johor*. Universiti Tun Hussein Onn Malaysia.
- Daly, S. R., Mosyjowski, E. A., & Seifert, C. M. (2014). Teaching creativity in engineering courses. *Journal of Engineering Education*, 103(3), 417–449. <https://doi.org/10.1002/jee.20048>
- Duda, H. J., Awang, I. S., & Andri, A. (2018). PKM Pelatihan Pemanfaatan Bahan Bekas Sebagai Media Pembelajaran IPA bagi Kelompok Guru IPA. *Jurnal Pengabdian Kepada Masyarakat*, 8(1), 15. <https://doi.org/10.30999/jpkm.v8i1.195>

- Ertmer, P. A. (2005). Teacher pedagogical beliefs: The final frontier in our quest for technology integration? *Educational Technology Research and Development*, 53(4), 25–39. <https://doi.org/10.1007/BF02504683>
- Etikan, I., & Bala, K. (2017). Sampling and Sampling Methods. *Biometrics & Biostatistics International Journal*, 5(6), 215–217. <https://doi.org/10.15406/bbij.2017.05.00149>
- Fajriati, N., & Murtiyasa, B. (2023). Kemampuan Literasi Matematika Siswa Menggunakan Multimedia Interaktif. *Jurnal Cendekia: Jurnal Pendidikan Matematika*, 07(1), 945–957.
- Fricker Jr, R. D. (2012). Sampling Methods for Web and email survey. In *The SAGE Handbook of Online Research Methods*. The SAGE Handbook of Online Research Methods. <https://doi.org/https://doi.org/10.4135/9780857020055.n11>
- Gralewski, J., & Karwowski, M. (2018). Are Teachers' Implicit Theories of Creativity Related to the Recognition of Their Students' Creativity? *Journal of Creative Behavior*, 52(2), 156–167. <https://doi.org/doi.org/10.1002/jocb.140>Citations: 54
- Gunawan, K. D. H., Liliyasi, S., Kaniawati, I., & Setiawan, W. (2020). Exploring science teachers' lesson plans by the implementation of intelligent tutoring systems in blended learning environments. *Universal Journal of Educational Research*, 8(10), 4776–4783. <https://doi.org/10.13189/ujer.2020.081049>
- Hair, J. F., Black, W. C., Babin, B. J., & Anderson, R. E. (2014). *Multivariate Data Analysis*. (Seventh). Pearson Educational Limited. <https://doi.org/10.2307/2007941>
- Hamdan, N., Mei Heong, Y., Jailani, A., Masran, S. H., Boon Ching, K., Tze Kiong, T., & Mohamad, M. M. (2021). Penggunaan Gaya Berfikir Dan Kemahiran Berfikir Aras Tinggi Bagi Menyelesaikan Masalah Dalam Penghasilan Produk: Analisis Keperluan. *Sains Insani*, 6(2). <https://doi.org/10.33102/sainsinsani.vol6no2.311>
- Hartini, S., Siregar, M., & Arifi, A. (2020). Implementasi pendidikan karakter di MTs Negeri Kabupaten Klaten. *Journal Basic Of Education*, 4(1), 14–29.
- Hidayat, D. N., Fitriah, Mahlil, & Mason, J. (2023). Factors Impacting English Teachers' Creativity in Teaching English as a Foreign Language in Indonesia. *Studies in English Language and Education*, 10(1), 155–173. <https://doi.org/10.24815/siele.v10i1.26145>
- Irfani, R. N. (2022). Peran Guru Dalam Meningkatkan Motivasi Belajar Siswa Pasca Pandemi Covid-19. *JISPE: Journal of Islamic Primary Education*, 3(1), 47–54. <https://doi.org/10.51875/jispe.v3i1.46>
- Kaviza, M., & Ibrahim, C. S. (2022). Penerokaan Stail Berfikir Sternberg dalam kalangan Murid Sejarah. *Malaysian Journal of Social Sciences and Humanities (MJSSH)*, 7(12), 1–9. <https://doi.org/https://doi.org/10.47405/mjssh.v7i12.2176> Penerokaan
- Kit, C. S., & Mahmud, M. S. (2023). Keberkesanan Pembelajaran Berasaskan Perisian Terhadap Penguasaan Geometri dalam kalangan Murid Tahun Enam : Sebuah Tinjauan Literatur ( Effectiveness of Software-Based Learning in Mastery Geometry among Year Six Students : A Literature Review ). *Malaysian Journal of Social Sciences and Humanities (MJSSH)*, 8(1), 1–9. <https://doi.org/https://doi.org/10.47405/mjssh.v8i1.2037>
- Maba, W., & Mantra, I. B. N. (2018). The primary school teachers' competence in implementing the 2013 curriculum. *SHS Web of Conferences*, 42. <https://doi.org/10.1051/shsconf/20184200035>
- Marimuthu, S., & Malayalam, N. (2020). Sosioekonomi Keluarga Sebagai Faktor Pendorong Gejala Gengsterisme Murid India Pendidikan Moral di Sekolah Menengah. *MJSSH: Muallim Journal of Social Science Ang Humanities*, 4(4), 60–78. <https://doi.org/https://doi.org/10.33306/mjssh/97>



- Mesran, M., Nasution, S. D., Suginam, S., Afriany, J., & Ramdhan, W. (2021). Optimalisasi Penggunaan Software Zoom dan Google Meet Dalam Meningkatkan Efektivitas Pembelajaran Daring. *Journal of Social Responsibility Projects by Higher Education Forum*, 2(2), 94–97. <https://doi.org/10.47065/jrespro.v2i2.987>
- Mishra, P., & Koehler, M. J. (2006). Technological Pedagogical Content Knowledge: A Framework for Teacher Knowledge. *Teachers College Record: The Voice of Scholarship in Education*, 108(6), 1017–1054. <https://doi.org/10.1177/016146810610800610>
- Mohamad, E. A., & Abd Karim, A. (2023). Analisis Keperluan: Pembangunan Modul DrawMe (DM) dalam Meningkatkan Kemahiran Matematik Berayat Sekolah Rendah. *Malaysian Journal of Social Sciences and Humanities (MJSSH)*, 8(3), 1–14. <https://doi.org/10.47405/mjssh.v8i3.2151>
- Mustafa, U. A. (2017). *Amalan Pengajaran Guru dan Kreativiti Pelajar Terhadap Strategi peluang perniagaan dalam kalangan pelajar pengajian keusahawanan Sekolah Menengah Teknik*. Universiti Putra Malaysia.
- Mohd Nor, R., Nik Yusoff, N. M. R., & Haron, H. (2020). Meneroka Kaedah Pengajaran Guru Cemerlang Pendidikan Seni Visual Selangor ( GCPSV ): Satu Kajian Kes Abstrak Exploring Teaching Method of Selangor Arts Excellent Teacher : A Case Study Abstract Pengenalan Metod Kajian. *Malaysian Journal of Social Sciences and Humanities (MJSSH)*, 5(5), 125–140. <https://doi.org/10.47405/mjssh.v5i5.394>
- Mohd Taib, M. T., & Mustapha, R. (2017). Kemudahan Prasarana Dalam Pelaksanaan Mata Pelajaran Teknologi Kejuruteraan, Lukisan Kejuruteraan dan Reka Cipta di Sekolah Menengah Harian Malaysia. *Sains Humanika*, 9(1–5). <https://doi.org/10.11113/sh.v9n1-5.1171>
- Muis, K. R., Psaradellis, C., Lajoie, S. P., Di Leo, I., & Chevrier, M. (2015). The role of epistemic emotions in mathematics problem solving. *Contemporary Educational Psychology*, 42, 172–185. <https://doi.org/185>. <https://doi.org/10.1016/j.cedpsych.2015.06.003>
- Mustaffa, Z., Hussin, Z., & Sulaiman, A. M. (2021). Kaedah Pengajaran Pedagogi Terbeza dalam konteks gaya belajar dan keadilan kepada murid : Pemikiran Imam Ibn Sahnun. *GJAT*, 11(2), 1–11.
- Namdar, B., & Kucuk, M. (2018). Preservice Science Teachers' Practices of Critiquing and Revising 5E Lesson Plans. *Journal of Science Teacher Education*, 29(6), 468–484. <https://doi.org/10.1080/1046560X.2018.1469188>
- Neuman, W. L. (2011). *Social Research Methods: Qualitative and Quantitative Approaches*. Allyn and Bacon.
- Ngatiman, S. (2018). *Konstruksi Amalan Kreativiti Pengajaran Guru Lukisan Kejuruteraan*. Tesis Sarjana. Universiti Teknologi Malaysia.
- Ngatiman, S., & Saud, M. S. (2022). Kajian Awal Tahap Amalan Kreativiti Pengajaran Guru Lukisan Kejuruteraan. In I. P. G. K. D. Aman (Ed.), *Prosiding SeDAR 2022* (pp. 394–413). Institut Pendidikan Guru Kampus Darulaman.
- Nurhayani, Yuanita, S. K. S., Permana, A. I., & Eliza, D. (2020). TPACK (Technological, Pedagogical, and Content Knowledge) untuk Peningkatan Profesionalisme Guru PAUD. *Jurnal Basicedu*, 6(1), 179–190. <https://doi.org/https://doi.org/10.31004/basicedu.v6i1.1852> ISSN
- Pasiangan, S., Hasbi, H., & Zainuddin, F. (2020). Counteracting the Social Media: The Role of Islamic Education Teachers' at SMAN 4 Tana Toraja. *International Journal of Asian Education*, 1(3), 169–178. <https://doi.org/https://doi.org/10.46966/ijae.v1i3.69>

- Patfield, S., Gore, J., Prieto, E., Fray, L., & Sincok, K. (2022). Towards quality teaching in higher education: pedagogy-focused academic development for enhancing practice. *International Journal for Academic Development*, 00(00), 1–16. <https://doi.org/10.1080/1360144X.2022.2103561>
- Ramadani, C., & Sutriyani. (2023). Concept of Arabic Language Learning Management Strategy in Madrasah. *Tanwir Arabiyyah: Arabic As Foreign Language Journal*, 3(1), 15–26. <https://doi.org/10.31869/aflj.v3i1.3958>
- Richards, J. C. (2010). Competence and Performance in Language Teaching. *102 RELC Journal*, 41(2), 101–122. <https://doi.org/10.1177/0033688210372953>
- Rushdi, N. M., & Amran, M. S. (2020). Kreativiti Dalam Proses Pengajaran dan Pembelajaran. *Persidangan Antarabangsa Sains Sosial Dan Kemanusiaan Ke-5 (PASAK5 2020)*, 322–332.
- Sahrir, M. S., Osman, N., & Muhammad, I. S. (2020). Aplikasi “Konsep 4C” Pembelajaran Abad ke-21 dalam Kalangan Guru Pelajar Sarjana Mod Pengajian Pendidikan Bahasa Arab Cuti Sekolah UIAM. *E-Jurnal Bahasa Dan Linguistik*, 2(1), 12–22. <http://ejbl.kuis.edu.my>
- Samsudin, M. Z., Hassan, R., Hasan, A., & Shamsuddin, M. A. D. (2013). Amalan kreativiti guru dalam Pengajaran Pendidikan Asas Vokasional (PAV). *Technology, Education and Science International Conference (TESIC), October 2014*, 1–11. <https://doi.org/10.13140/2.1.4265.2161>
- Sari, L. M. (2019). Evaluasi dalam Pendidikan Islam. *Al-Tadzkiyyah: Jurnal Pendidikan Islam*, 9(2), 211–231. <https://doi.org/10.24042/atjpi.v9i2.3624>
- Sarifuddin, N., & Ahmad, A. (2023). Keberkesanan Pembelajaran Kooperatif Menggunakan Kaedah Jigsaw II dalam Penulisan Esei Sejarah. *Malaysian Journal of Social Sciences and Humanities (MJSSH)*, 8(1), 2504–8564. <https://doi.org/10.47405/mjssh.v8i1.2030>
- Seng, O. J., & Othman, S. (2018). Tahap Pengetahuan dan sikap Guru terhadap pendekatan didik hiburan dalam pengajaran Bahasa Melayu. *International Journal of Education and Training*, 4(2), 1–9.
- Setiawan, A., Munir, A., & Suhartono, S. (2019). Creative Teachers in Teaching Speaking Performance. *Pedagogy: Journal of English Language Teaching*, 7(2), 75–86. <https://doi.org/10.32332/pedagogy.v7i2.1670>
- Sidek, R., Halim, L., Buang, N. A., & Mohamad Arsad, N. (2020). Fostering Scientific Creativity in Teaching and Learning Science in Schools: A Systematic Review. *Jurnal Penelitian Dan Pembelajaran IPA*, 6(1), 13. <https://doi.org/10.30870/jppi.v6i1.7149>
- Wang, X. (2022). Piano Information Teaching Mode Based on Deep Learning Algorithm. *Wireless Communications and Mobile Computing*, 2022, 1–10. <https://doi.org/https://doi.org/10.1155/2022/6205763>
- Wirawan, R., Awal Nur, M., & Syahraeni, R. (2020). Aplikasi Pembelajaran Matematika Interaktif Berbasis Multimedia. *JARTIKA : Jurnal Riset Teknologi Dan Inovasi Pendidikan*, 3(1), 75–83. <https://doi.org/10.36765/jartika.v3i1.28>
- Yasin, R., Mustapha, R., Minghat, A. D., Jusoff, K., Ishar, A., & Shamsudin, S. (2012). Pelaksanaan Pengajaran dan Pembelajaran Mata Pelajaran Lukisan Kejuruteraan di Sekolah Menengah. *Asia Pacific Journal of Educators and Education*, 27, 23–36. [https://doi.org/10.1016/0304-3835\(85\)90058-8](https://doi.org/10.1016/0304-3835(85)90058-8)
- Yonkaitis, C. F. (2020). Lesson plan basics: Teaching in the classroom with confidence. *Nasn School Nurse*, 35(3), 136–139. <https://doi.org/https://doi.org/10.1177/1942602x19893038>