

Factor Structure and Validation of the Chinese Version of the Mazzarolo Music Performance Anxiety Scale (M-MPAS-Cn)

Qian Liu, Mei Foong Ang*

Department of Music, Faculty of Human Ecology, Universiti Putra Malaysia, Serdang, Selangor, Malaysia

Email: gs64139@student.upm.edu.my

Corresponding Author Email: meifoong@upm.edu.my

DOI Link: <http://dx.doi.org/10.6007/IJARBSS/v16-i4/28046>

Published Date: 21 April 2026

Abstract

Music Performance Anxiety (MPA) is a common experience among student musicians; however, there are limited validated brief screening tools for Chinese populations. This study followed established guidelines to translate, back-translate, and examine the psychometric properties of the Chinese version of the Mazzarolo Music Performance Anxiety Scale (M-MPAS-Cn). Exploratory Factor Analysis (EFA; $n = 217$) and Confirmatory Factor Analysis (CFA; $n = 323$) were conducted using data collected from undergraduate music students from two distinct samples. EFA showed a preference for a single-factor model, which accounted for 68.43% of the variance. Good model fit across different indices was confirmed by CFA. Standardized loadings are all $> .60$, and both composite reliability ($CR = .878$) and average variance extracted ($AVE = .599$) met recommended thresholds. These results indicate that the M-MPAS-Cn has high reliability, validity, and a consistent unidimensional structure and is a reliable candidate for the short and effective screening of Chinese music learners for MPA. This study further highlights the practical significance of providing a rapid and culturally appropriate screening tool, which can support early identification of music performance anxiety among Chinese-speaking music students and inform timely educational and psychological interventions in both academic and clinical contexts.

Keywords: Music Performance Anxiety, M-MPAS-Cn, Exploratory Factor Analysis, Confirmatory Factor Analysis, Reliability and Validity

Introduction

Music performance anxiety (MPA) is defined as “a specific state of arousal that occurs periodically when musicians present themselves to an audience in a performance situation” (Spahn, 2015, p. 129). Conceptually, MPA is commonly defined to be comprised of four interlocking components: somatic, behavioral, cognitive, and emotional (Kenny, 2011; Spahn, 2015). People with MPA often report certain physiological symptoms, such as rapid heart rate,

excessive sweating, shaking, dry mouth or throat, difficulty breathing, muscle tension, gastrointestinal distress, and dizziness (Kenny, 2011; Nagel, 2017). These symptoms not only affect the quality of musical performance but may also impair students' learning experiences, self-confidence, and long-term engagement in music education. Therefore, understanding and effectively identifying MPA is of critical importance for both educational and psychological support systems in music training contexts.

MPA is also defined as a performance-specific form of Social Anxiety Disorder (SAD), fitting in with the diagnostic toolkit for the Diagnostic and Statistical Manual of Mental Disorders (American Psychiatric Association, 2013). SAD is usually categorized as generalized (anxiety over interpersonal areas), non-generalized (anxiety only on being observed or surveilled), and specific subtypes (anxiety restricted to a particular set of performance sites) (Turner et al., 2003). SAD is usually categorized as generalized (anxiety over interpersonal areas), non-generalized (anxiety only on being observed or surveilled), and specific subtypes (anxiety restricted to a particular set of performance sites) (Kenny, 2011).

Prevalence and Influencing Factors

MPA has been reported to be diagnosed in various ethnic populations and in different settings of performance. It has been found in empirical research, including in professional musicians (Cohen & Bodner, 2019; Mazzon et al., 2024), amateur performers (Spahn et al., 2023), singers (Henshaw & Collyer, 2022), pianists (Passarotto et al., 2023), dancers (Clegg & Clements, 2024), music students (Barros et al., 2022; Huang & Yu, 2022), adolescents (Ananias de Lima et al., 2024), and young children (Tardif et al., 2024).

Demography and environment, and in particular sex, age, and level of competence, influence MPA (Ioulia Papageorgi et al., 2007). Generally, MPA levels are higher in females than in males (Driscoll et al., 2014; Gómez-López & Sánchez-Cabrero, 2024; Jónsdóttir, 2010). Younger artists often experience more severe MPA than older musicians (Fernholz et al., 2019; Steptoe, 2001). Anxiety has been recorded in both solo and ensemble settings (Barros et al., 2024; Burin & Osório, 2017), while certain situations, such as performing solo (Jiang & Tong, 2024; Rife et al., 2000), performing from memory (Hamann & Sobaje, 1983), and auditions (Kenny, 2011; Wilson & Roland, 2002), seem to induce high anxiety. However, reviews report variation among studies and consistently estimate an MPA occurrence rate of anywhere from 15–70% among professional musicians (Barros et al., 2024; Burin & Osório, 2017; Steptoe, 2001).

The prevalence of MPA found among university music students in China has been consistently reported (Jiang & Tong, 2024; Ou & Qin, 2025; Yang, 2025; Yang et al., 2025). Relatedly, more than 70% of Taiwanese college music undergraduates are affected (Lin, 2019), pointing to a clear concern for the Chinese-speaking population. The high prevalence of MPA in this population underscores the urgent need for efficient and accessible assessment tools that can be used in large-scale educational settings. Without appropriate screening instruments, many students experiencing elevated anxiety may remain unidentified and unsupported, potentially affecting both their academic performance and psychological well-being.

Assessment of Music Performance Anxiety

Evaluation of music performance anxiety Various psychometric tools have been created for evaluating the degree of MPA, such as the Music Performance Stress Survey (MPSS; Brodsky et al., 1994), the Performance Anxiety Scale for Music Students (PASMS; Cirakoglu & Sentürk, 2013), the Kenny Music Performance Anxiety Inventory (K-MPAI; Kenny et al., 2004), the Music Performance Anxiety Questionnaire (MPAQ; Lehrer et al., 1990), the Music Performance Anxiety Inventory for Adolescents (MPAI-A; Osborne & Kenny, 2005), the Adolescent Musicians' Performance Anxiety Scale (AMPAS; I. Papageorgi, 2007, 2021), and two versions of the Music Performance Anxiety Scale (Sheriff & Yoong, 2015; Wolfe, 1989).

However, the rapid assessment of MPA still lacks in China. The current study attempts to fill such a gap by exploring the translation and validation of the short-form instrument Mazzarolo Music Performance Anxiety Scale (M-MPAS) established by Mazzarolo and Schubert (2022), which offers short and global measures of MPA experience. Although such concise tools are not adequate substitutes for multidimensional diagnostic instruments, they have practical value for fast screening for use in clinical, research and experimental settings. In particular, brief screening tools are highly valuable in educational contexts where time constraints and large student populations make the use of lengthy multidimensional instruments impractical. Such tools enable teachers and practitioners to quickly identify at-risk individuals and make timely decisions regarding further assessment or intervention. Crucially, it is also shown that even the most brief psychological scales can exhibit acceptable reliability.

There is currently no Chinese translation of the M-MPAS, and the appropriateness of this instrument for Chinese undergraduate music students has not been established. Since the prevalence of MPA is high, it is essential to develop valid, reliable assessment tools based on the Chinese cultural and linguistic context. Developing a valid and reliable short-form screening instrument in Chinese is therefore not only theoretically important but also practically necessary. It can directly benefit music educators, clinicians, and researchers by providing a convenient tool for early detection, monitoring, and evaluation of MPA, ultimately contributing to improved student well-being and performance outcomes.

Therefore, this study aimed to conduct an initial validation of the Mazzarolo Music Performance Anxiety Scale (M-MPAS-Cn) in the Chinese context. The specific objectives were as follows:

1. To translate and validate the Chinese version of the Mazzarolo Music Performance Anxiety Scale (M-MPAS-Cn) for cross-cultural application.
2. To perform an exploratory factor analysis (EFA) to examine the reliability and validity of the M-MPAS-Cn.
3. To conduct confirmatory factor analysis (CFA) on M-MPAS-Cn and evaluate its reliability and validity.
4. To examine the applicability of the M-MPAS-Cn for use among Chinese undergraduate music students.

Methods

Participants

To achieve substantial validity of the instrument in a Chinese setting, data was collected in 2 stages including exploratory factor analysis (EFA) and confirmatory factor analysis (CFA).

EFA Sample

The EFA sample consisted of 217 undergraduate music students recruited from two universities in Shanxi Province, China. The eligibility criteria were that participants must have taken and completed a solo performance examination. Participants ranged in age from 18 to 23 ($M = 20$, $SD = 1.603$), and the sample consisted of 145 females (66.8%) and 72 males (33.2%). 72.8% were vocal majors and 27.2% instrumental majors. Demographic information is shown in Table 1.

Table 1

Demographic Characteristics of Participants for the EFA Stage

		Frequency	Percent	Valid Percent	Cumulative Percent
Gender	Females	145	66.8	66.8	66.8
	Males	72	33.2	33.2	100
	Total	217	100	100	
Major	instrument	59	27.2	27.2	27.2
	vocal	158	72.8	72.8	100
	Total	217	100	100	

Source: Authors' work

CFA Sample

CFA Sample. The CFA sample comprised 323 undergraduate music students at the two universities. Inclusion criteria were again determined to be identical to the EFA stage and necessitated completion of a solo examination. Participants ranged in age from 18 to 23 years ($M = 19.8$, $SD = 1.432$), with 203 females (62.8%) and 120 males (37.2%). Vocal and instrumental majors accounted for 77.4 and 22.6% of the sample, respectively. Demographic characteristics are shown in Table 2.

Table 2

Demographic Characteristics of Participants for the CFA Stage

		Frequency	Percent	Valid Percent	Cumulative Percent
Gender	Females	203	62.8	62.8	62.8
	Males	120	37.2	37.2	100
	Total	323	100	100	
Major	instrument	73	22.6	22.6	22.6
	vocal	250	77.4	77.4	100
	Total	323	100	100	

Source: Authors' work

Instrument

The Mazzarolo Music Performance Anxiety Scale (M-MPAS) was created by Mazzarolo and Schubert (2022) and is a short self-report screening instrument for measuring frequency,

intensity, and avoidance related to music performance anxiety (MPA). The scale includes 5 items, rated on a Likert-type standardized scale, which result in a total rating score of 0–30; scores of 11 or above indicate higher levels of MPA.

The M-MPAS possesses substantial psychometric properties including good internal consistency (Cronbach's $\alpha = .894$); strong construct validity as assessed by a high correlation with MPA instruments used already ($r = .791$). Its low duration and simplicity to use make it especially good for short-term screening and initial triage use in research, educational settings, and clinical practice (Mazzarolo & Schubert, 2022).

Procedure

Translation and Cultural Adaptation

The study commenced with a comprehensive multi-step translation procedure to realize conceptual and linguistic equivalence of using M-MPAS with Chinese participants (Duda & Hayashi, 1998; Tanzer & Sim, 1999).

The scale was first translated into Chinese by a bilingual researcher from the field of music psychology. A bilingual teacher later confirmed the translation for correctness and clarity, and modified terms of expression to more accurately convey the natural Chinese usage. For back-translation, a second bilingual teacher who did not understand the content of the original instrument translated the Chinese version back into English. Discrepancies between the back-translated version and the original versions were examined and revisions were made iteratively until the conceptual and linguistic alignment was complete as recommended for a translation validation protocol (Duda & Hayashi, 1998).

The Chinese version of the scale (M-MPAS-Cn) was in the second stage administered to the EFA sample. Exploratory factor analysis was conducted to study factor structure and select the most suitable factor measures for retention. The psychometric evaluation of M-MPAS-Cn (reliability and validity) was also performed. A reassessment of measurement quality is necessary when adapting, adjusting, and translating scales to a new culture (Wang, 1999).

In Stage three, the M-MPAS-Cn was applied to the CFA sample. Confirmatory factor analysis was performed to assess the nature of the factors observed from the EFA and evaluate the reliability and validity of the instrument.

Ethical Considerations and Data Collection Procedures

The study received ethical approval from the University Putra Malaysia Ethics Committee for Research Involving Human Subjects (JKEUPM-2023-1413).

Participants were recruited via the music departments of two universities. The data were obtained using the online platform Wen JuanXing (wjx). Participation guidelines, confidentiality rules, and voluntary nature were included on the survey homepage. After students completed solo performance examinations, university instructors communicated the survey link to students across WeChat groups. It takes around 20 minutes to complete. After data collection, data in SPSS were processed.

Participation in the study was completely voluntary with students being informed of their right to withdraw at any time with no adverse consequences. Confidentiality was maintained and electronic consent was obtained. Participants were also informed that no financial compensation would be provided. All individuals provided consent for their anonymized data to be used for research, presentation, and publication purposes.

Results

Results of the Exploratory Factor Analysis (EFA) of the M-MPAS-Cn

Table 3

Descriptive statistical analysis of the M-MPAS-Cn.

	N	Minimum	Maximum	Mean	Std. Deviation	Skewness	Kurtosis
MMPAS1	217	0	6	3.54	1.453	.045	-.323
MMPAS2	217	0	6	3.55	1.440	-.055	-.233
MMPAS3	217	0	6	2.34	1.614	.281	-.342
MMPAS4	217	0	6	3.38	1.502	-.027	-.306
MMPAS5	217	0	6	2.83	1.786	.033	-.692
Valid N (listwise)	217						

Source: Authors' work

Table 3 presents the descriptive statistics for the Chinese version of the M-MPAS (M-MPAS-Cn). The sample consists of 217 students. The values range from a minimum of 0 to a maximum of 6, with an average between 2 and 4. The absolute values of skewness and kurtosis are less than 1, indicating that the data follows a univariate normal distribution.

Table 4

KMO and Bartlett's Test

Kaiser-Meyer-Olkin Measure of Sampling Adequacy.		.799
	Approx. Chi-Square	759.186
Bartlett's Test of Sphericity	df	10
	Sig.	.000

Source: Authors' work

Table 4 presents the results of the KMO and Bartlett's tests. With a KMO value greater than 0.7, factor analysis can be performed. The p-value is less than .001, indicating a correlation between the items.

Table 5

Factor structure of the M-MPAS-Cn.

Component Matrixa						
Component						
						1
MMPAS2						.928
MMPAS1						.918
MMPAS4						.879
MMPAS3						.736
MMPAS5						.635
Extraction Method: Principal Component Analysis						
a 1 components extracted.						
Total Variance Explained						
Component	Initial Eigenvalues			Extraction Sums of Squared Loadings		
	Total	% of Variance	Cumulative %	Total	% of Variance	Cumulative %
1	3.422	68.431	68.431	3.422	68.431	68.431
2	.841	16.83	85.261			
3	.454	9.072	94.333			
4	.182	3.633	97.966			
5	.102	2.034	100			
Extraction Method: Principal Component Analysis.						

Source: Authors' work

Table 5 shows the factor structure of the M-MPAS-Cn which has 1 dimension in total and explains 68.43% of the variance. Following Hair's (1995) recommendations, factor loadings are above 0.6, cross-loadings are below 0.35 (Hair et al., 1995), and no items are associated with other dimensions. As a result, all items can be retained.

Table 6

Reliability analysis table for M-MPAS-Cn

	MMPA S1	MMPA S2	MMPA S3	MMPA S4	MMPA S5	Corrected Correlation	Item-Total	Cronbach's Alpha
MMPA S1	1					.837		.872
MMPA S2	.887	1				.816		
MMPA S3	.435	.448	1			.520		
MMPA S4	.820	.845	.371	1		.751		
MMPA S5	.591	.507	.537	.485	1	.626		

Source: Authors' work

Table 6 presents the reliability analysis for M-MPAS-Cn. Following Hair's (2010) recommendations, the item-to-total correlations are above 0.5, the inter-item correlations exceed 0.3, with a Cronbach's alpha exceeding 0.7 (Hair et al., 2010). This dimension

demonstrates adequate reliability and internal consistency, and no items need to be removed.

Table 7
Convergent Validity and Reliability of the M-MPAS-Cn

	Reliability	Convergent Validity	Descriptive Statistics
Dimension	Cronbach's alpha	AVE	N
M-MPAS-Cn	.872	.684	217

Source: Authors' work

Table 7 presents the analysis of reliability, convergent validity. The table includes data from 217 samples. Cronbach's alpha is above 0.7 while AVE exceeds 0.5, meeting the standards recommended by Hair et al., (2010). This means that each dimension has reliability and convergent validity.

Results of the Confirmatory Factor Analysis (CFA) of the M-MPAS-Cn

Table 8
Descriptive statistical analysis of the M-MPAS-Cn.

	N	Minimum	Maximum	Mean	Std. Deviation	Skewness	Kurtosis
MMPAS1	323	0	6	3.59	1.477	-.075	-.448
MMPAS2	323	0	6	3.61	1.462	-.183	-.275
MMPAS3	323	0	6	2.89	1.667	-.010	-.522
MMPAS4	323	0	6	3.36	1.535	-.158	-.220
MMPAS5	323	0	6	2.75	1.818	.045	-.881
Valid N (listwise)	323						

Source: Authors' work

Table 8 presents the descriptive statistics for the Chinese version of the M-MPAS (M-MPAS-Cn). There are 323 students in the sample. The range of values is minimum zero to maximum six, and the average is between 2 and 4. Since the skewness and kurtosis are less than 1, the data is univariate normal.

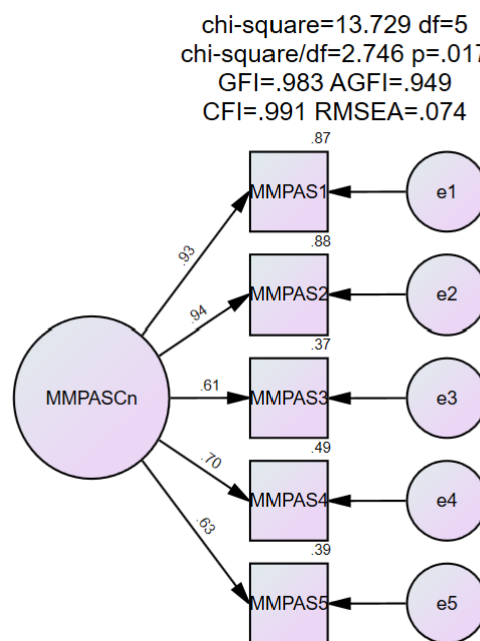

Figure 1. First-Order Confirmatory Factor Analysis of the M-MPAS-Cn (Single-Factor Model)
 Source: Authors’ work

Figure 1 shows results of first-order confirmatory factor analysis (CFA) on the M-MPAS-Cn single-factor model. The model demonstrated an acceptable overall fit to the data: $\chi^2(5) = 13.729$, $p = .017$; $\chi^2/df = 2.746$; GFI = .983; AGFI = .949; CFI = .991; RMSEA = .074.

Per established model fit criteria, χ^2/df value less than 3 describes good model fit (Kline, 2016); GFI, AGFI, and CFI above .90 are considered acceptable, and values above .95 indicate excellent fit (Hu & Bentler, 1999); RMSEA values under .08 is an acceptable approximation error (Browne & Cudeck, 1993). Based on these thresholds, the M-MPAS-Cn single-factor model demonstrates an acceptable to good fit across all indices.

Table 9
Convergent Validity and Reliability of the M-MPAS-Cn.

Dimension	Item	Parameter estimates		significance		factor loadings	Item reliability	Composite Reliability	Convergent Validity
		Unstd.	S.E.	t-value	P	Std.	SMC	CR	AVE
M-MPAS-Cn	MMPAS 1	1				.931	.867	.878	.599
	MMPAS 2	.995	.036	27.40	**	.936	.876		
	MMPAS 3	.736	.058	12.59	**	.607	.368		
	MMPAS 4	.785	.050	15.76	**	.703	.494		
	MMPAS 5	.827	.063	13.14	**	.625	.391		

Source: Authors’ work

Table 9 contains the parameter significance estimates, standardized factor loadings, item reliabilities (SMC), composite reliability (CR), and average variance extracted (AVE) for M-MPAS-Cn single-factor model. All standardized factor loadings were between .607 to .936 exceeding the recommended cutoff of .60 (Fornell & Larcker, 1981), implying that all items were strongly loaded on the latent construct. The squared multiple correlations (SMC) values for all items were $> .36$, indicating adequate item reliability.

The value of composite reliability (CR) was found to be .878, which was significantly greater than the recommended value of .70 (Hair et al., 2010), as it indicates the good internal consistency of the construct. The average variance extracted (AVE) was .599, exceeding the .50 criterion according to Fornell and Larcker (1981), the criterion of acceptable convergent validity.

Overall, these findings demonstrate that the M-MPAS-Cn single-factor model has reliable convergent validity and good stability.

Discussion

This study aimed to translate, examine the factor structure, and evaluate the psychometric properties of the Chinese version of the Mazzarolo Music Performance Anxiety Scale (M-MPAS-Cn) among undergraduate music students in Shanxi Province. Thus, in summary, the results of this study support the generalizability of the M-MPAS-Cn as a short, reliable and valid screening instrument for music performance anxiety (MPA) in this population. Importantly, the effectiveness of the M-MPAS-Cn lies in its ability to provide rapid yet psychometrically sound assessment, making it particularly suitable for repeated use in educational and intervention contexts.

The exploratory factor analysis indicated a unidimensional structure that accounted for 68.43% of the variance, and all items demonstrated factor loadings above the recommended threshold ($> .60$) (Hair et al., 1995). These results align with the original design intent of the M-MPAS as a concise global measure of MPA experience (Mazzarolo & Schubert, 2022). The unidimensional solution is consistent with prior short-form MPA measures that emphasize rapid assessment of the overall experience of performance anxiety rather than its multifaceted symptom clusters (e.g., frequency, intensity, avoidance) used in longer instruments (Lehrer et al., 1990; Mazzarolo & Schubert, 2022).

Confirmatory factor analysis provided further support for the single-factor model. Model fit indices ($\chi^2/df = 2.746$; GFI = .983; AGFI = .949; CFI = .991; RMSEA = .074) indicate acceptable to excellent fit by commonly used thresholds (Browne & Cudeck, 1993; Hu & Bentler, 1999; Kline, 2016). The relatively small χ^2 value and $\chi^2/df < 3$ suggest the model reproduces the observed covariance structure adequately (Kline, 2016). High standardized loadings (.607–.936), SMCs $> .36$, composite reliability (CR = .878), and AVE = .599 together demonstrate that the single latent construct is measured consistently and explains a meaningful proportion of item variance (Fornell & Larcker, 1981; Hair et al., 2010). In short, the CFA results corroborate the EFA findings and indicate satisfactory internal structure and convergent validity for the M-MPAS-Cn.

The psychometric profile observed here is comparable to validation studies of other brief MPA scales and short-form psychological measures more generally, which have

demonstrated that succinct instruments can achieve satisfactory reliability and validity when carefully developed and validated (Hair et al., 2010; Mazzarolo & Schubert, 2022). The high internal consistency (Cronbach's $\alpha > .70$) and item-total statistics of this study confirm that the M-MPAS-Cn can be used as an effective screening tool in contexts where time or respondent burden are a concern (Hair et al., 2010).

From a practical perspective, the availability of a validated Chinese short-form measure offers several benefits. First, it enables teachers, practitioners, and researchers at Chinese schools to quickly screen for elevated MPA or to triage students who require additional evaluation or treatment. Second, due to the close mapping of the M-MPAS-Cn to the original English scale, cross-cultural comparisons and multi-site studies are more possible, thus facilitating the wider investigation of prevalence, correlates, and intervention effects in other cultural contexts (Mazzarolo & Schubert, 2022). In this regard, the instrument serves as a practical bridge between research and real-world application, benefiting not only researchers but also frontline educators and mental health practitioners working with music students.

The present findings also speak to theoretical considerations in MPA research. Although numerous instruments conceptualize MPA across somatic, cognitive, behavioral, and emotional domains (Kenny, 2011; Spahn, 2015), the M-MPAS-Cn's unidimensional structure suggests that, for rapid screening purposes, a global index of MPA experience can capture meaningful variance associated with performance anxiety. This does not negate the value of multidimensional measures for in-depth clinical assessment, but it supports a pragmatic measurement approach for large-scale screening or repeated monitoring (Kenny, 2011).

Several limitations should be acknowledged. First, the samples were drawn exclusively from undergraduate students at two universities in Shanxi Province and were predominantly classical-oriented; thus, the generalizability of the findings to older performers, non-student populations, and musicians of other genres (e.g., jazz, pop, folk) is limited. Future validation work should include more diverse age groups, professional musicians, and different musical styles (Barros et al., 2024; Clegg & Clements, 2024).

Second, the present study relied on self-report data collected via an online survey, which may introduce response biases (e.g., social desirability) and does not allow for clinical diagnostic confirmation of SAD or performance-specific anxiety. Where possible, future research could triangulate self-report scores with behavioral, physiological, or clinician-rated assessments to establish criterion validity.

Third, although the translation process followed recommended multi-step procedures (Duda & Hayashi, 1998; Tanzer & Sim, 1999), more extensive cultural equivalence testing, such as cognitive interviews with participants or differential item functioning (DIF) analyses, would strengthen claims about item interpretation equivalence across linguistic groups. Moreover, longitudinal validation (e.g., test-retest reliability) was not conducted here and should be included in subsequent studies to establish temporal stability.

Given the high prevalence of MPA reported among Chinese music students in previous studies (Jiang & Tong, 2024; Ou & Qin, 2025; Yang et al., 2025), a brief validated screening tool such as the M-MPAS-Cn has immediate utility for educational institutions and mental health services. Early identification of elevated MPA enables timely referrals for targeted interventions (e.g., cognitive-behavioral techniques, performance skills training, relaxation and attention strategies) and allows researchers to evaluate intervention effectiveness using a standardized brief outcome measure.

Conclusions

This study provides initial empirical support for the Chinese version of the Mazarolo Music Performance Anxiety Scale (M-MPAS-Cn). Both exploratory and confirmatory factor analyses endorse a unidimensional structure that accounts for a substantial proportion of variance, and psychometric indicators, including factor loadings, SMCs, composite reliability, and AVE, meet commonly accepted thresholds for reliability and convergent validity (Fornell & Larcker, 1981; Hair et al., 2010; Hu & Bentler, 1999). Collectively, these results indicate that the M-MPAS-Cn is a promising brief instrument for the rapid screening of MPA among Chinese undergraduate music students. More importantly, the availability of this brief instrument addresses a critical gap in the Chinese context, where efficient and culturally appropriate screening tools for MPA have been limited.

Given the study limitations related to sample composition and methodology, the M-MPAS-Cn should be further validated in more diverse samples and with additional validity evidence. Nevertheless, this research represents a necessary first step toward accessible, culturally appropriate measurement of music performance anxiety in Chinese musical contexts and provides a foundation for both applied screening and further scholarly investigation into the determinants and treatment of MPA. Beyond its psychometric contribution, this study emphasizes the broader educational and clinical relevance of early MPA identification, supporting the development of targeted interventions and promoting healthier performance experiences among music students.

Acknowledgments

Gratitude is extended to all study participants.

References

- American Psychiatric Association. (2013). *Diagnostic and Statistical Manual of Mental Disorders*. American Psychiatric Association. <https://doi.org/10.1176/appi.books.9780890425596>
- Ananias de Lima, A., Christine Cavalcanti Ximenes, R., & Lopes de Souza, S. (2024). Factors associated with music performance anxiety in adolescents: A systematic review. *Children and Youth Services Review*, 164, 107860. <https://doi.org/10.1016/j.childyouth.2024.107860>
- Barros, S., Marinho, H., Borges, N., & Pereira, A. (2022). Characteristics of music performance anxiety among undergraduate music students: A systematic review. *Psychology of Music*, 50(6), 2021–2043. <https://doi.org/10.1177/03057356211066967>
- Barros, S., Marinho, H., & Pereira, A. (2024). Music performance anxiety in Portuguese higher education: Contextual factors, perceptions, and strategies. *Musicae Scientiae*, 28(2), 287–307. <https://doi.org/10.1177/10298649231202977>

- Brodsky, W., Sloboda, J. A., & Waterman, M. G. (1994). An exploratory investigation into auditory style as a correlate and predictor of music performance anxiety. *Med. Probl. Perform. Art.*, 9, 101–112.
- Browne, M. W., & Cudeck, R. (1993). Alternative ways of assessing model fit. In Bollen, K. A. & Long, J. S. (Eds.), *Testing structural equation models* (pp. 136–162). Sage.
- Burin, A. B., & Osório, F. L. (2017). Music performance anxiety: a critical review of etiological aspects, perceived causes, coping strategies and treatment. *Archives of Clinical Psychiatry (São Paulo)*, 44(5), 127–133. <https://doi.org/10.1590/0101-60830000000136>
- Cirakoglu, O. C., & Sentürk, G. C. (2013). Development of a performance anxiety scale for music students. *Med. Probl. Perform. Art.*, 28, 199–206.
- Clegg, H., & Clements, L. (2024). From the Wings to the Stage and Beyond: Performance Anxiety and Flow in UK Vocational Dance Students. *Journal of Dance Education*, 24(2), 83–94. <https://doi.org/10.1080/15290824.2021.2004604>
- Cohen, S., & Bodner, E. (2019). The relationship between flow and music performance anxiety amongst professional classical orchestral musicians. *Psychology of Music*, 47(3), 420–435. <https://doi.org/10.1177/0305735618754689>
- Driscoll, T., Ackermann, B., & Kenny, D. T. (2014). Psychological well-being in professional orchestral musicians in Australia: A descriptive population study. *Psychology of Music*, 42(2), 210–232. <https://doi.org/10.1177/0305735612463950>
- Duda, J. L., & Hayashi, C. T. (1998). *Measurement issues in cross-cultural research within sport and exercise psychology*. MorFitness Information Technology.
- Fernholz, I., Mumm, J. L. M., Plag, J., Noeres, K., Rotter, G., Willich, S. N., Ströhle, A., Berghöfer, A., & Schmidt, A. (2019). Performance anxiety in professional musicians: a systematic review on prevalence, risk factors and clinical treatment effects. *Psychological Medicine*, 49(14), 2287–2306. <https://doi.org/10.1017/S0033291719001910>
- Fornell, C., & Larcker, D. F. (1981). Evaluating Structural Equation Models with Unobservable Variables and Measurement Error. *Journal of Marketing Research*, 18(1), 39–50. <https://doi.org/10.1177/002224378101800104>
- Gómez-López, B., & Sánchez-Cabrero, R. (2024). Design and Evaluation of a Collective Preventive Program for Musical Performance Anxiety (ConfiDance). *European Journal of Investigation in Health, Psychology and Education*, 14(5), 1260–1278. <https://doi.org/10.3390/ejihpe14050083>
- Hair, J. F., Anderson, R. E., Tatham, R. L., & Black, W. C. (1995). *Multivariate data analysis with readings (4th ed.)*. Multivariate data analysis with readings (4th ed.).
- Hair, J. F., Black, W. C., Babin, B. J., & Anderson, R. E. (2010). *Multivariate Data Analysis (7th ed.)*. Pearson Education.
- Hamann, D. L., & Sobaje, M. (1983). Anxiety and the college musician: A study of performance conditions and subject variables. *Psychology of Music*, 11(1), 37–50. <https://doi.org/10.1177/0305735683111005>
- Henshaw, A., & Collyer, S. (2022). Under Pressure: Reports of Performance Anxiety Across Multiple Singing Genres. *Journal of Singing*, 78(5), 583–590. <https://doi.org/10.53830/JETA7812>
- Hu, L. T., & Bentler, P. M. (1999). Cutoff criteria for fit indexes in covariance structure analysis: Conventional criteria versus new alternatives. *Structural Equation Modeling*, 6(1), 1–55.
- Huang, W. L., & Yu, H. (2022). Social support in university music students' coping with performance anxiety: people, strategies and performance situations. *Music Education Research*, 24(1), 124–135. <https://doi.org/10.1080/14613808.2022.2028752>

- Jiang, X., & Tong, Y. (2024). Psychological capital and music performance anxiety: the mediating role of self-esteem and flow experience. *Frontiers in Psychology, 15*. <https://doi.org/10.3389/fpsyg.2024.1461235>
- Jónsdóttir, I. (2010). Music performance anxiety among musicians and methods they use to deal with it. In *[Unpublished BSc thesis]*. University of Iceland.
- Joseph F. Hair, J., Black, W. C., Babin, B. J., & Anderson, R. E. (2009). *Multivariate Data Analysis*. pp 816.
- Kenny, D. T. (2011). *The psychology of music performance anxiety*. Oxford University Press.
- Kenny, D. T., Davis, P., & Oates, J. (2004). Music performance anxiety and occupational stress amongst opera chorus artists and their relationship with state and trait anxiety and perfectionism. *Journal of Anxiety Disorders, 18*(6), 757–777. <https://doi.org/10.1016/j.janxdis.2003.09.004>
- Kline, R. B. (2016). *Principles and practice of structural equation modeling* (4th ed). Guilford Press.
- Lehrer, P. M., Goldman, N., & Strommen, E. . (1990). A principal components assessment of performance anxiety among musicians . *Medical Problems of Performing Artists, 5*, 12–18.
- Lin, M. C. (2019). *An investigation of music performance anxiety in taiwanese pianists, vocalists, string and wind instrumentalists at the college level* (Issue August). University of North Dakota in.
- Mazzarolo, I., & Schubert, E. (2022). A Short Performance Anxiety Scale for Musicians. *Frontiers in Psychology, 12*. <https://doi.org/10.3389/fpsyg.2021.781262>
- Mazon, L., Passarotto, E., Altenmüller, E., & Vercelli, G. (2024). Music performance anxiety and the Italian sport psychology S.F.E.R.A. model: An explorative study on 77 professional musicians. *Psychology of Music, 52*(3), 322–339. <https://doi.org/10.1177/03057356231198239>
- Nagel, J. J. (2017). *Managing stage fright: A guide for musicians and music teachers*. New York: Oxford University Press.
- Osborne, M. S., & Kenny, D. T. (2005). Development and validation of a music performance anxiety inventory for gifted adolescent musicians. *Journal of Anxiety Disorders, 19*(7), 725–751. <https://doi.org/10.1016/j.janxdis.2004.09.002>
- Ou, J., & Qin, C. (2025). Exploring musical self-efficacy and performance anxiety in young violin learners: insights from mainland China. *Frontiers in Psychology, 16*. <https://doi.org/10.3389/fpsyg.2025.1575591>
- Papageorgi, I. (2007). *Understanding Performance Anxiety in the Adolescent Musician*. London: UCL Institute of Education.
- Papageorgi, I. (2021). Typologies of Adolescent Musicians and Experiences of Performance Anxiety Among Instrumental Learners. *Frontiers in Psychology, 12*. <https://doi.org/10.3389/fpsyg.2021.645993>
- Papageorgi, Ioulia, Hallam, S., & Welch, G. F. (2007). A conceptual framework for understanding musical performance anxiety. *Research Studies in Music Education, 28*(1), 83–107. <https://doi.org/10.1177/1321103X070280010207>
- Passarotto, E., Worschech, F., & Altenmüller, E. (2023). The effects of anxiety on practice behaviors and performance quality in expert pianists. *Frontiers in Psychology, 14*. <https://doi.org/10.3389/fpsyg.2023.1152900>

- Rife, N., Lapidus, L., & Shnek, Z. (2000). Musical Performance Anxiety, Cognitive Flexibility, and Field Independence in Professional Musicians. *Medical Problems of Performing Artists, 15*(4), 161–166.
- Sheriff, F. H. M., & Yoong, C. Y. (2015). Development of the music performance anxiety scale. *Int. J. Acad. Res. Reflec, 3*, 1–9.
- Spahn, C. (2015). Treatment and prevention of music performance anxiety. In E. Altenmüller, S. Finger, & F. Boller (Eds.), *Progress in Brain Research* (Vol. 127, pp. 129–140). <https://doi.org/10.1016/bs.pbr.2014.11.024>
- Spahn, C., Tenbaum, P., Immerz, A., Hohagen, J., & Nusseck, M. (2023). Dispositional and performance-specific music performance anxiety in young amateur musicians. *Frontiers in Psychology, 14*. <https://doi.org/10.3389/fpsyg.2023.1208311>
- Steptoe, A. (2001). Negative Emotions In Music Making: The Problem Of Performance Anxiety. In *Music And Emotion* (pp. 291–308). Oxford University Press New York, NY. <https://doi.org/10.1093/oso/9780192631886.003.0013>
- Tanzer, N. K., & Sim, C. Q. E. (1999). Adapting instruments for use in multiple languages and cultures: A review of the ITC guidelines for test adaptations. *European Journal of Psychological Assessment, 15*, 258–269.
- Tardif, C., Boucher, H., Lane, J., & Barbeau, A. (2024). Music performance anxiety in children 9–12 years old in a music program. *Psychology in the Schools, 61*(2), 671–685. <https://doi.org/10.1002/pits.23079>
- Turner, S. M., Johnson, M. R., Beidel, D. C., Heiser, N. A., & Lydiard, R. B. (2003). The Social Thoughts and Beliefs Scale: A New Inventory for Assessing Cognitions in Social Phobia. *Psychological Assessment, 15*(3), 384–391. <https://doi.org/10.1037/1040-3590.15.3.384>
- Wang, X. D. (1999). *Rating scales for mental health*. Beijing, China: Chinese Mental Health Journal Press.
- Wilson, G. D., & Roland, D. (2002). Performance Anxiety. In R. Parncutt & G. McPherson (Eds.), *The Science & Psychology of Music Performance* (pp. 47–61). Oxford University Press. <https://doi.org/10.1093/acprof:oso/9780195138108.003.0004>
- Wolfe, M. L. (1989). Correlates of adaptive and maladaptive musical performance anxiety. *Med. Probl. Perform. Art, 4*, 49–56.
- Yang, Y. (2025). *Traditional Chinese values and perfectionism: Impacts on MPA in Chinese piano students*. Queen's University Belfast.
- Yang, Y., Lei, P., Huang, Z., Yu, H., & Zhang, H. (2025). The impact of professional music performance competence on performance anxiety: the mediating role of psychological risk and moderating role of psychological resilience. *Frontiers in Psychology, 16*. <https://doi.org/10.3389/fpsyg.2025.1565215>