



INTERNATIONAL JOURNAL OF ACADEMIC RESEARCH IN BUSINESS & SOCIAL SCIENCES



The Influence of Work Environment, Competence and Compensation on Employee Performance through Intervening Variable Job Satisfaction at Bank BJB Tangerang Branch

Setyani Dwi Lestari, Dindin A. Syabarudin, Cut Zurnali, Dina Fitria Murad

To Link this Article: <http://dx.doi.org/10.6007/IJARBSS/v8-i11/5280> DOI: 10.6007/IJARBSS/v8-i11/5280

Received: 06 Nov 2018, **Revised:** 29 Nov 2018, **Accepted:** 02 Dec 2018

Published Online: 03 Dec 2018

In-Text Citation: (Lestari, Syabarudin, Zurnali, & Murad, 2018)

To Cite this Article: Lestari, S. D., Syabarudin, D. A., Zurnali, C., & Murad, D. F. (2018). The Influence of Work Environment, Competence and Compensation on Employee Performance through Intervening Variable Job Satisfaction at Bank BJB Tangerang Branch. *International Journal of Academic Research in Business and Social Sciences*, 8(11), 1572–1580.

Copyright: © 2018 The Author(s)

Published by Human Resource Management Academic Research Society (www.hrmars.com)

This article is published under the Creative Commons Attribution (CC BY 4.0) license. Anyone may reproduce, distribute, translate and create derivative works of this article (for both commercial and non-commercial purposes), subject to full attribution to the original publication and authors. The full terms of this license may be seen

at: <http://creativecommons.org/licenses/by/4.0/legalcode>

Vol. 8, No. 11, 2018, Pg. 1572 - 1580

<http://hrmars.com/index.php/pages/detail/IJARBSS>

JOURNAL HOMEPAGE

Full Terms & Conditions of access and use can be found at
<http://hrmars.com/index.php/pages/detail/publication-ethics>



INTERNATIONAL JOURNAL OF ACADEMIC RESEARCH IN BUSINESS & SOCIAL SCIENCES



The Influence of Work Environment, Competence and Compensation on Employee Performance through Intervening Variable Job Satisfaction at Bank BJB Tangerang Branch

Setyani Dwi Lestari, Dindin A. Syabarudin, Cut Zurnali, Dina Fitria Murad

¹²³Magister Management, Budi Luhur University, Jakarta, Indonesia

⁴Bina Nusantara University, Jakarta, Indonesia

Email: Setyani.dwilestari@budiluhur.ac.id, dindinsyabarudin79@gmail.com,
lolly_zurnali@yahoo.com, dinafitriamurad@gmail.com

ABSTRACT

This study aims to analyze the influence of Work Environment, Competence and Compensation Against Employee Performance Through Intervening Variable Job Satisfaction At Bank BJB Tangerang Branch. In essence, performance is the end result to be achieved by an organization. Achievement of good performance will not be realized without the support of qualified human resources. The object of research in this research is employees of Bank BJB Branch Tangerang, which amounts to 80 people. So the authors take the object of research on employees of Bank BJB Branch Tangerang, where all the population used as the subject of research and no sample research, then this study using the census method. The method of analysis used is Structural Equation Modeling (SEM). The results of this study indicate that (1) Work Environment has positive and significant effect on Job Satisfaction, (2) Competence has positive and significant effect on Job Satisfaction, (3) Compensation has positive and significant effect to Job Satisfaction, (4) (6) Competence has a positive and significant impact on Employee Performance, (7) Compensation has positive and significant impact to Employee Performance, (8) Work Environment, Competence And Compensation Simultaneously on Work Satisfaction, and (9) Work Environment, Competence, Compensation, and Job Satisfaction Simultaneously affect Towards Employee Performance.

Keywords: Employee Performance, BJB Bank, Structural Equation Modelling

INTRODUCTION

Human resources is an organizational assets are very vital, because it's presence in the organization or company cannot be replaced by other resources. No matter how modern the technology is used or how much money is prepared but without the support of human resources with professional skills

it all becomes meaningless. Thus human resources play a very strategic role because human beings organize all processes within the organization (Prasetyo, 2014).

Often the performance of employees decreased due to inconvenience in work, minimal compensation, capacity or skills that are less supportive and also dissatisfaction in work. Employee job satisfaction must be taken seriously by every company. Dissatisfaction becomes the starting point for the emergence of problems in organizations and companies such as absenteeism, employee-employee conflict, high absenteeism, strikes and employee turnover. From the worker side, dissatisfaction can lead to decreased motivation, decreased work morale, and decreased appearance of work both qualitatively and quantitatively. High job satisfaction will have a positive impact on employees such as the incidence of loyalty and discipline to the work and will improve the performance of these employees.

In essence, performance is the end result to be achieved by an organization. Achievement of good performance will not be realized without the support of qualified human resources. Assessment of employee performance at BJB Bank Tangerang Branch has been done with one way system which means the appraisal on employee performance is done by direct supervisor or leader and is subjective so that employees never know the ability and weakness so far. While the results of a well-regarded employee performance appraisal will have a direct impact on the employee's promotion while for employees who are considered to be performing poorly will get a certain punishment.

Employee performance appraisal is conducted annually which includes: job understanding, accuracy in work, speed of work completion, work volume and efficiency in doing the job. While the talent or potential is assessed from: initiative, attitude, cooperation, ability, responsibility and discipline. Information gained from the results of employee performance appraisal is very important as a basis for decision making and should be a feedback for organizational progress.

Based on the conditions in the background description above, can be formulated some problems as follows:

1. Does the work environment affect the performance of employees of Bank BJB Tangerang Branch?
2. Does the competence affect the performance of Bank BJB employees Tangerang Branch?
3. Does compensation affect the employee performance of Bank BJB Tangerang Branch?
4. Does job satisfaction affect the performance of employees of Bank BJB Tangerang Branch?
5. Does the work environment affect the job satisfaction of employees of Bank BJB Tangerang Branch?
6. Does competence affect employee satisfaction of Bank BJB Tangerang Branch?
7. Does compensation affect employee satisfaction of Bank BJB Tangerang Branch?
8. Does the work environment, competence, and compensation simultaneously have a significant effect on job satisfaction?
9. Does the work environment, competence, compensation, and job satisfaction together (simultaneously) have a significant effect on employee performance?

Performance

Performance is the result achieved by employees in their work according to certain criteria that apply to a particular job and evaluated by certain people. According to Husnan (2010), one will achieve high

performance depending on cooperation, personality, versatility, leadership, safety of work knowledge, presence, toughness and initiative.

Performance can be interpreted as the ratio between inputs generally to output (Dessler 2009). Performance is the result of work in quality and quantity achieved by an employee in performing their duties in accordance with the responsibilities given to him (Mangkunegara 2009). In addition, performance can also be interpreted as a result and one's efforts are achieved with the ability and deeds in certain situations.

Work Environment

According Sedarmayanti (2011) work environment as follows: Work environment is the whole tooling tools and materials facing the surrounding environment where a person works, methods of work, and arrangement of work, both as individuals and as a group. Meanwhile, according Wibowo (2013) work environment can be interpreted as the forces that affect, either directly or indirectly to the performance of the organization or company. Meanwhile, according to Robbins and Judge (2013) work environment is a situation around the workplace both physically and non-physical that can give the impression of fun, secure, reassuring, and feel at work. According to Nitisemito (2008) the work environment is everything that is around the workers who can affect himself in carrying out the tasks embedded.

Competence

Competence according to Manullang (2008) is as basic characteristics possessed by an individual who relates causally in meeting the criteria required in occupying a position. Competence consists of 5 types of characteristics, ie motives (consistent willingness as well as the cause of action), innate factors (consistent character and response), self-concept (self-image), knowledge (information in a particular field) and skills (ability to perform task). This is in line with the opinion of Robbins and Judge (2013) that competency refers to an individual's knowledge, skill, ability or personality characteristics that affect job performance. That is, competence contains aspects of knowledge, skills (skills) and ability or personality characteristics that affect performance.

Compensation

Wibowo (2013) defines compensation as what workers receive in exchange for their contribution to the organization. Hasibuan (2012) argues that compensation is all income in the form of money, goods directly or indirectly received by employees in exchange for remuneration provided by the company. A similar thing is put forward by Dessler (2009) where he says that compensation is any form of payment or compensation paid to employees and arises from the employment of the employee.

Job Satisfaction

According to Wibowo (2013) job satisfaction is a general attitude towards one's work, which shows the difference between the number of awards received by workers and the amount they believe they should receive. In Wibowo (2013) describes job satisfaction as a positive or negative attitude that individuals do to their work. A similar view was also expressed by Gibson (2007) who expressed job

satisfaction as the attitude that workers have about their work. it is the result of their perception of work. According Sutrisno (2010) job satisfaction is basically a sense of security (security feeling) and has aspects of social and economic aspects (salary and social security) and social aspects of psychology that is the opportunity to move forward, the opportunity to get a job, related to supervisory issues, with the association between employees with their superiors.

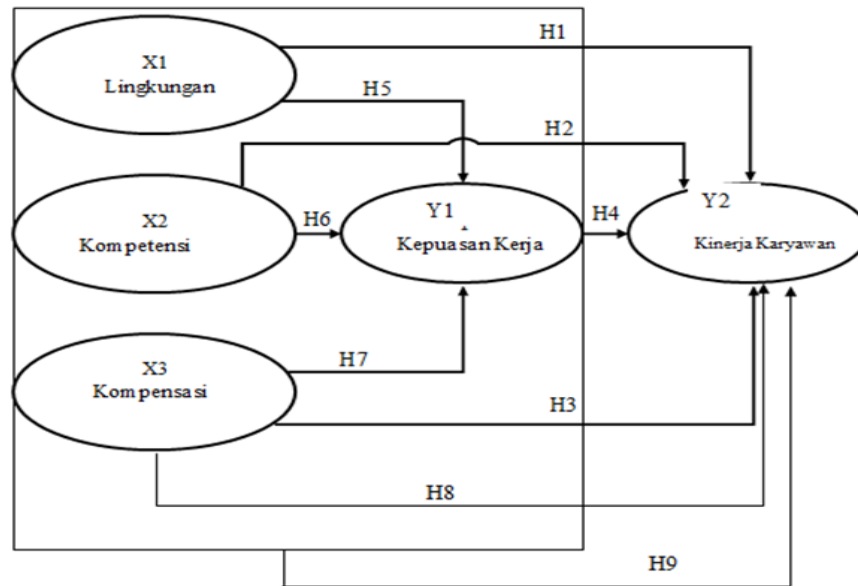

Fig. 1: Framework

Hypothesis

Based on Figure 1, these are the hypotheses of this study:

- H1. There is a positive and significant influence between work environment on Job Satisfaction of Bank BJB Tangerang Branch.
- H2. There is a positive and significant influence between competence on employee performance of Bank BJB Tangerang Branch.
- H3. There is a positive and significant influence between the compensation on the performance of Bank BJB employees Tangerang Branch.
- H4. There is a positive and significant influence between job satisfaction on employee performance of Bank BJB Tangerang Branch.
- H5. There is a positive and significant influence between the work environment on employee job satisfaction of Bank BJB Tangerang Branch.
- H6. There is a positive and significant influence between competence on employee job satisfaction of Bank BJB Tangerang Branch.
- H7. There is a positive and significant influence between the compensation on employee job satisfaction of Bank BJB Tangerang Branch.
- H8. There is an influence of working environment, competence, and compensation simultaneously (on simultaneous) to job satisfaction of employee of Bank BJB Tangerang Branch.
- H9. There is influence of work environment, competence, compensation and job satisfaction together (simultaneously) to the performance of BJB Branch employee of Tangerang Branch.

METHOD

Population is defined as a collection of elements or elements that become the object of research (here human being referred to). This population element is usually a unit of analysis. Population is the set of all the things you want to know. The population in the study can also be interpreted as a whole unit of analysis whose characteristics will be suspected. The unit of analysis is the unit / unit to be researched or analyzed. Population in this research is employees of Bank BJB Branch of Tangerang, which amounts to 80 people, so the population is less than 100, the authors take the object of research on employees of Bank BJB Branch Tangerang, where all population is used as research subjects and no sample research, this uses the census method.

The census method is used for the reason that the writer wants to know employee behavior where the employee behavior is different for each employee, so it will be more accurate result if using census method. According Sugiyono (2007) suggests if the number of respondents or subjects in the employee population of less than 100 people in the study using a questionnaire, preferably the subject is taken entirely or no samples. So the subjects in the study amounted to 80 employees ie all employees at Bank BJB Tangerang Branch taken as a whole.

According to Ghozali (2013), to perform complete SEM modeling, the following steps should be taken:

1. The first step: Development of Theoretical Model
2. The second step: Forming a Chart Diagram (Path Diagram)
3. Third step: Convert Flowchart into Equation
4. Fourth step: Selecting Input Matrix and Model Estimation
5. The fifth step: Assessing the Identification Problem
6. Sixth Step: Evaluation of Goodnes of Fit Criteria
7. The seventh step: Interpretation and Modification of the Model

RESULT AND DISCUSSION

TABLE 1: Interpretation of Research Results

Influence between variables			Estimate	S.E.	C.R.	P
Job satisfactory	<---	Work Environment	,173	,086	2,010	,044
Job satisfactory	<---	Competence	,132	,151	2,877	,022
Job satisfactory	<---	Compensation	,103	,132	2,780	,000
Employee Performance	<---	Job satisfactory	,135	,149	2,904	,030
Employee Performance	<---	Work Environment	,113	,096	2,177	,000
Employee Performance	<---	Competence	,182	,174	2,046	,006
Employee Performance	<---	Compensation	,196	,150	2,644	,000

Based on research result presented in table 1, it can be concluded:

1. Work Environment has a positive and significant impact on Job Satisfaction. It is based on the value of C.R $2,010 \geq 1.96$ and the value of P $0.044 \leq 0.05$ (Ghozali 2013). Based on that, the hypothesis "Accepted". The contribution of Work Environment to Motivation (R²) is 0,259 or 25,9%.
2. Competence has a positive and significant impact on Job Satisfaction. It is based on the value of C.R $2,877 \geq 1.96$ and the value of P $0.022 \leq 0.05$ (Ghozali 2013). Based on that, the hypothesis "Accepted". The contribution of Competence to Motivation (R²) is 0.311 or 31.1%.
3. Compensation has a positive and significant impact on Job Satisfaction. It is based on the value of C.R $2,780 \geq 1.96$ and the value of P $0,000 \leq 0.05$ (Ghozali 2013). Based on that, the hypothesis "Accepted". The contribution of Compensation to Job Satisfaction (R²) of 0.397 or 39.7%.
4. Job Satisfaction has a positive and significant impact on Employee Performance. It is based on the value of C.R $2,904 \geq 1.96$ and the value of P $0.030 \leq 0.05$ (Ghozali 2013). Based on that, the hypothesis "Accepted". The contribution of Job Satisfaction on Employee Performance (R²) of 0.222 or 22.2%.
5. Work Environment has a positive and significant impact on Employee Performance. It is based on the value of C.R $2,177 \geq 1.96$ and the value of P $0,000 \leq 0.05$ (Ghozali 2013). Based on that, the hypothesis "Accepted". The contribution of Work Environment to Employee Performance (R²) is 0,253 or 25,3%.
6. Competence has a positive and significant impact on Employee Performance. It is based on R $2,046 \geq 1.96$ and P value $0.006 \leq 0.05$ (Ghozali 2013). Based on that, the hypothesis "Accepted". The contribution of Competence to Employee Performance (R²) of 0.239 or 23.9%.
7. Compensation has a positive and significant effect on Employee Performance. It is based on R $2,644 \geq 1.96$ and P $0,000 \leq 0.05$ (Ghozali 2013). Based on that, the hypothesis "Accepted". The contribution of Compensation to Employee Performance (R²) of 0.282 or 28.2%.

TABLE 2 : Coefficient Determination Test Results

Endogen Variables	Structural Equation Model (SEM)	SMC
Job Satisfactory	$\beta_1 WE + \beta_2 CT + \beta_3 CO + z_1$	0,486
Employee Performance	$\beta_1 WE + \beta_2 CT + \beta_3 CO + \beta_4 EP + z_2$	0,576

Based on Table 2:

1. The magnitude of the effect of exogenous variables (Work Environment, Competence, Compensation) on Job Satisfaction of 0.486 or 48.6%. While the remaining 51.4% influenced by other variables. The value of C.R of 16.076 ($2.010 * 2.877 * 2.780$) so it can be concluded significant.
2. The influence of exogenous variables (Work Environment, Competence, Compensation, Job Satisfaction) on Employee Performance of 0.576 or 57.6%. While the remaining 42.4% influenced by other variables. The value of C.R is 34,199 ($2,904 * 2,177 * 2,046 * 2,644$) so it can be concluded significant.

CONCLUSION

1. Work Environment has a positive and significant impact on Job Satisfaction. A comfortable impression of the work environment can reduce the feeling of boredom and boredom in work. Comfort of course will have an impact on increasing motivation and generate employee job satisfaction.
2. Competence has a positive and significant impact on Job Satisfaction. Competence can affect the job satisfaction, the more have a high competence it will cause a high job satisfaction as well.
3. Compensation has a positive and significant impact on Job Satisfaction. job satisfaction is an attitude of employees to work related to work situations, cooperation among employees, benefits received in the work.
4. Job Satisfaction has a positive and significant impact on Employee Performance. Job satisfaction is an individual matter so that there will be dynamics or changes every time that must be anticipated so as not to evolve in the direction of things that are negative that detrimental to the agency.
5. Work Environment has a positive and significant impact on Employee Performance. Such as the perception of the employees about the work environment that they get so that employees can provide different assessment of all aspects of the work environment. If the perception shown by employees is good then it will affect the employee's performance is good also because it can make the employees feel more comfortable and fun with the state of a good work environment
6. Competence has a positive and significant impact on Employee Performance. In the performance of each employee will not be separated from the competencies possessed by an employee and the state of the work environment within an organization where they work. Competence is the initial capital of the employees that must be owned to be able to occupy a certain position and carry out the work.
7. Compensation has a positive and significant effect on Employee Performance. Effective and efficient compensation can directly establish the stability of the organization, and indirectly contribute to promoting the stability and growth of the country's economy as a whole.
8. Working Environment, Competence and Compensation Simultaneously (Together) to the effect of Job Satisfaction. Job satisfaction is basically something that is individual. Each individual has a different level of satisfaction in accordance with the value system that applies to him.
9. Working Environment, Competence, Compensation, and Job Satisfaction Simultaneously (Together) effect on Employee Performance. Good management and quality human resources are needed by the company for the achievement of the company's main objectives. Attitudes and behavior of employees who benefit or disadvantage the company can be seen from the high low quality of employee performance in the company.

REFERENCES

- Dessler, G. (2009). *Manajemen Sumber Daya Manusia*. Jakarta: PT Indeks.
- Ghozali, I. (2013). *Model Persamaan Struktural Konsep & Analisis Dengan Program AMOS 21*. Semarang: UNDIP Press.
- Gibson, J. L. (2007). *Organisasi, Perilaku, Struktur dan Proses*. Jakarta: Penerbit Erlangga.
- Hasibuan, M.S.P. (2012). *Manajemen Sumber Daya Manusia*. Jakarta: PT BumiAksara.
- Husnan, S. (2007). *Manajemen Keuangan*. Edisi Kelima. Yogyakarta: UPP AMP YKPN.
- Mangkunegara, A. P. (2009). *Manajemen Sumber Daya Manusia Perusahaan*. Bandung: PT Remaja Rosdakarya.
- Manullang. (2008). *Dasar-Dasar Manajemen*. Yogyakarta: Ghalia Indonesia
- Nitisemito, A. S. (2008). *Manajemen Personal*. Jakarta: Ghalia Indonesia.
- Prasetyo, S. (2014). *Pengaruh Gaya Kepemimpinan dan Kompensasi terhadap Kinerja Karyawan dengan Kepuasan Kerja sebagai Variabel Intervening (Studi pada Hotel Berbintang di Yogyakarta)*. Thesis. Universitas Negeri Yogyakarta.
- Robbins, S.P., & Judge, T. A. (2013). *Perilaku Organisasi*. Edisi 16. Jakarta: Salemba Empat.
- Sedarmayanti. (2011). *Manajemen Sumber Daya Manusia, Reformasi Birokrasi Manajemen Pegawai Negeri Sipil*. Bandung: Rafika Aditama.
- Sugiyono. (2007). *Metodologi Penelitian Bisnis*. Jakarta: PT. Gramedia.
- Sutrisno, E. (2010). *Manajemen Sumber Daya Manusia*. Jakarta: Kencana.
- Wibowo. (2009). *Manajemen Kinerja*. Jakarta: PT. Raja Grafindo Persada.