



## Designing a Stock Trading System Using Artificial Neuro Fuzzy Inference Systems and Technical Analysis Approach

Fatemeh Faghani, Mehdi Abzari, Saeid Fathi, Seyed Amir Hassan Monajemi

To Link this Article: <http://dx.doi.org/10.6007/IJARAFMS/v4-i1/542>

DOI:10.6007/IJARAFMS /v4-i1/542

**Received:** 14 January 2014, **Revised:** 17 January 2014, **Accepted:** 24 February 2014

**Published Online:** 10 March 2014

**In-Text Citation:** (Faghani et al., 2014)

**To Cite this Article:** Faghani, F., Abzari, M., Fathi, S., & Monajemi, S. A. H. (2014). Designing a Stock Trading System Using Artificial Neuro Fuzzy Inference Systems and Technical Analysis Approach. *International Journal of Academic Research in Accounting Finance and Management Sciences*. 4(1), 108-120.

**Copyright:** © 2014 The Author(s)

Published by Human Resource Management Academic Research Society ([www.hrmars.com](http://www.hrmars.com))

This article is published under the Creative Commons Attribution (CC BY 4.0) license. Anyone may reproduce, distribute, translate and create derivative works of this article (for both commercial and non-commercial purposes), subject to full attribution to the original publication and authors. The full terms of this license may be seen at: <http://creativecommons.org/licenses/by/4.0/legalcode>

**Vol. 4, No. 1, 2014, Pg. 108 - 120**

<http://hrmars.com/index.php/pages/detail/IJARAFMS>

**JOURNAL HOMEPAGE**

Full Terms & Conditions of access and use can be found at  
<http://hrmars.com/index.php/pages/detail/publication-ethics>



# Designing a Stock Trading System Using Artificial Neuro Fuzzy Inference Systems and Technical Analysis Approach

Fatemeh Faghani<sup>1</sup>, Mehdi Abzari<sup>2</sup>, Saeid Fathi<sup>3</sup>, Seyed Amir Hassan Monajemi<sup>4</sup>

<sup>1,2,3</sup>Faculty of Administration and Economic Science, Department of Management, University of Isfahan, Isfahan, Iran, <sup>4</sup>University of Isfahan, Faculty of Engineering, Department of Computer, Isfahan, Iran

Email: f.faghani1367@gmail.com, (Corresponding author), Mabzari32@yahoo.com, fathiresearch@yahoo.com, monadjemi@eng.ui.ac.ir

## Abstract

This paper has been designed a stock trading systems using Artificial Neuro Fuzzy Inference Systems (ANFIS) and technical analysis approach. The proposed model receives 14 last days information and predicts 14 next day's variables' values Simple Moving Average (SMA), Exponential Moving Average (EMA), Moving Average Convergence - Divergence (MACD), Relative Strength (RSI) , stochastic oscillator (SO) using ANFIS. Then, the net output are changed to signal of buy and sell after apply trading rules. In the next step, the final signal is created by the sum of generated signals. Thus, buy and sale will propose during the next 14 days. Performance Designed systems were studied for 17 shares. Results showed that the mean of all generated networks Percentage of correct predictions (96/55%) is more than random cases (50 %). Given the positive returns SMA ,EMA ,SO and proposed method It's can be results that using these indices of technical analysis can predict trading optimal time of Iran stock market.

**Keywords:** Technical Analysis, Fuzzy Neural Networks, Trading System, Tehran Stock Exchange

## Introduction

The investment and capital accumulation has an important role in economic development of the country. This importance can clearly be seen in capitalism countries. Undoubtedly, stock market is one of the best positions to attract small capital stock and use them to develop a corporate (Shams and Asghari, 2009). The stock market Investors like to know the best time trading to obtain maximum possible return. Access to such information only is possible if there is awareness to stock's future status. This awareness needs to a predicting the future tools. Technical analysis and intelligent systems are the most common forecasting methods are used in the financial field. Thus, In this research tried to design an intelligence system that can be present buy and sell optimum time by Technical Analysis and Artificial Neuro Fuzzy Inference Systems (ANFIS) benefits, So, main objective of the present

study is to evaluate the ability of ANFIS network and technical analysis combined model in forecasting buy/sell signals. In this regard, the research hypotheses are stated as follows:

The main assumptions: the ability of ANFIS network and technical analysis combined model in forecasting buy/sell signals is at an appropriate level.

Sub-hypotheses:

1-1. Percentage of correct prediction presented models is more than random (50%).

1-2. there is significant differences between return of proposed trading method and buy/hold method before deduction of transaction costs.

1-3. there is significant differences between return of proposed trading method and buy/hold method after deduction of transaction costs.

## Literature Review

### **Technical Analysis**

"Technical Analysis" is included so many techniques that try to forecasting future price with study past prices. In technical analysis, the past movement of stock prices and supply/demand forces affecting stock price is important. Time that an investor starts to trade depend on his expect of future stock price. An investor bought stock if is confident that stock price will increase, and he will sell it if is expected to stock price will fall. In other words, people sold the stock because they think it has not value. Charles Dow was the first person in mid-19th century that published articles about technical analysis in Journal WSJ. Today, most technical indicators are based on Dow Theory. New methods of technical analysis are completed by Dow Theory focus on stock prices movement, (Emami *et al.*, 2007). However, most technical analysis indicators have been developed over the past 70 years. Indicators and oscillating are the most important technical analysis tools.

### **Artificial Neuro Fuzzy Inference Systems**

Different structures have been proposed for a fuzzy system implementation by neural networks. One of their most powerful is Artificial Neuro Fuzzy Inference Systems that was developed by Jrys (Sarfaraz and Afsar, 2005). Fuzzy- neural networks are separate rules without have need to implicit formulation. ANFIS consists of if-then rules and couples of input-output. Also for ANFIS training, learning algorithms of neural network are used.

To simplify the explanations, the fuzzy inference system under consideration is assumed to have two inputs (x and y) and one output (z). For a first order of Sugeno fuzzy model, a typical rule set with base fuzzy if-then rules can be expressed as:

If x is  $A_1$  and y is  $B_1$  then  $f_1 = p_1x + q_1y + r_1$

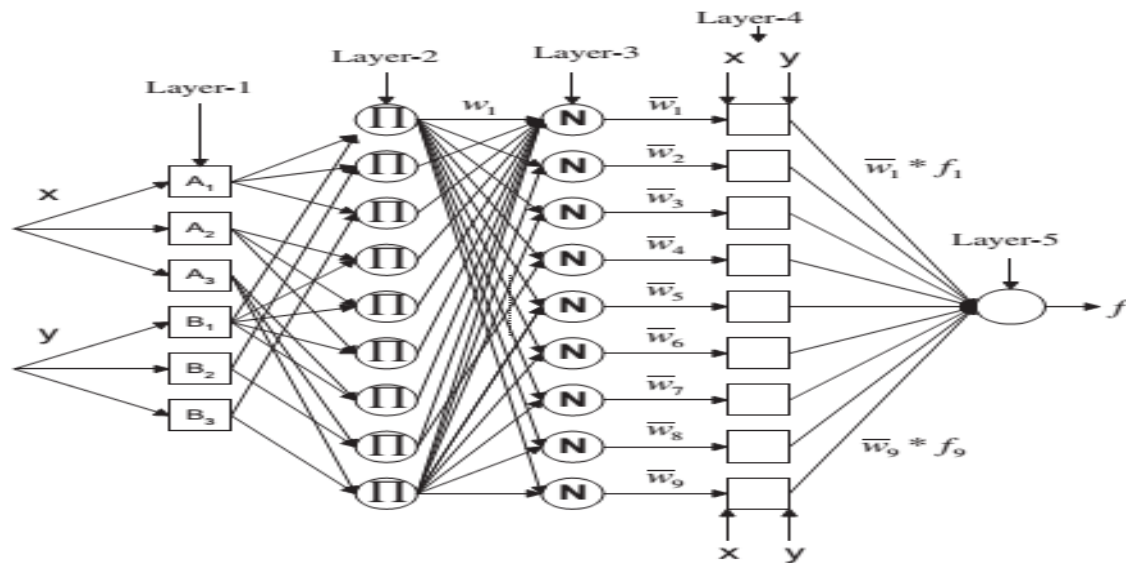

Figure 1. ANFIS architecture of two inputs and nine rules

Where p, r, and q are linear output parameters. The ANFIS' architecture with two inputs and one output is as shown in Fig. 1. This architecture is formed by using five layers and nine if-then rules:

Layer-1: Every node i in this layer is a square node with a nodefunction.

$$O_{1,i} = \mu_{A_i}(x), \text{ for } i = 1, 2, 3 \quad O_{1,i} = \mu_{B_{i-3}}(y), \text{ for } i = 4, 5, 6$$

Where x and y are inputs to node i, and A<sub>i</sub> and B<sub>i</sub> are linguistic labels for inputs. In other words, O<sub>1,i</sub> is the membership function of A<sub>i</sub> and B<sub>i</sub>. Usually  $\mu_{A_i}(x)$  and  $\mu_{B_i}(y)$  are chosen to be bell-shaped with maximum equal to 1 and minimum equal to 0, such as;

$$\mu_{A_i}(x), \mu_{B_{i-3}}(y) = \exp\left(\frac{-(x_i - c_i)^2}{a_i^2}\right)$$

Where a<sub>i</sub>, c<sub>i</sub> is the parameter set. These parameters in this layer are referred to as premise parameters.

Layer-2: Every node in this layer is a circle node labeled Π which multiplies the incoming signals and sends the product out. For instance,

$$O_{2,i} = w_i = \mu_{A_i}(x) \cdot \mu_{B_{i-3}}(y), \quad i = 1, 2, 3, \dots, 9$$

Each node output represents the firing strength of a rule.

Layer-3: Every node in this layer is a circle node labeled N. The ith node calculates the ratio of the ith rules firing strength to the sum of all rule's firing strengths:

$$O_{3,i} = \bar{w}_i = w_i / (w_1 + w_2 + \dots + w_9), \quad i = 1, 2, 3, \dots, 9$$

Layer-4: Every node i in this layer is a square node with a node function

$$O_{4,i} = \bar{w}_i \cdot f_i = w_i \cdot (p_i x + q_i y + r_i), \quad i = 1, 2, 3, \dots, 9$$

Where w<sub>i</sub> is the output of layer 3 and {p<sub>i</sub>, q<sub>i</sub>, r<sub>i</sub>} is the parameter set. Parameters in this layer will be referred to as consequent parameters.

Layer-5: The single node in this layer is a circle node labeled  $\Sigma$  that computes the overall output as the summation of all incoming signals ( Boyacioglu and Avci, 2010):

$$O_{5,i} = \text{overall output} = \sum_i \bar{w}_i f_i = \frac{\sum_i w_i f_i}{\sum_i w_i}$$

Previous researchers have been confirmed the feasibility of the technical indicators such as moving averages to predict the trend of stock price (Mohammadi, 2004, Emami *et al*, 2007; Setayesh *et al*, 2008; Nabavi Chashemi and Hassan zadeh, 2011). As is clear from Table 1, in most previous research has been approved intelligent systems' ability to predict stock price trends and their application in the design of trading systems stock.

Table 1  
*Summary of related research in the field of stock trading systems*

Brief of Results	Network type	Researchers
Artificial neural networks have the ability to predict short-term stock prices trends in Tehran Stock Exchange.	Back propagation Networ(BPN)	Tehrani and Abbasion, 2011
Evaluation results indicate that the neural network considering both the quantitative and qualitative factors excels the neural network considering only the quantitative factors both in the clarity of buying-selling points and buying-selling performance	Genetic Algorithm Neural Network (GANN)	Kuo et al, 2001
The best results obtained by the ANN had an mean absolute percentage error around 50% smaller than the best benchmark, and doubled the capital of the investor.	Artificial Neural Network (ANN)	Martinez et al, 2006
Experimental results showed that the proposed model identified rules with greater interpretability and yielded significantly higher profits than the stock trading with DENFIS forecast model and the stock trading without forecast model	Rough Set-based Pseudo Outer-Product (RSPOP)	Keng Ang and Queck, 2006
The Percentage of Winning Trades was increased significantly from an average of 70% to more than 92% using the system as compared to the conventional trading system.	RSPOP	Tan et al, 2008
The empirical results show that the CBDW can assist the BPN to reduce the false alarm of buying or selling decisions.	Case Based Dynamic Window Neural Network (CBDWNN)	Chang et al, 2009
The experimental results show that the IPLR approach can make significant amounts of profit on stocks with different variations. In conclusion, the proposed system is	Integrating a Piecewise Linear Representation Method and a Neural Network Model	Chang et al, 2009

Brief of Results	Network type	Researchers
very effective and encouraging in that it predicts the future trading points of a specific stock.		
The overall results indicate that the proportion of correct predictions and the profitability of stock trading guided by these neural networks are higher than those guided by their benchmarks	feed-forward neural network (FNN), Probabilistic Neural Network (PNN), Learning Vector Quantization Network (LVQ)	Thawronwong et al, 2010
The high return of the proposed method is shown high performance of the proposed method	Multilayer Perceptron (MLP)	Kordos and cwiok, 2011

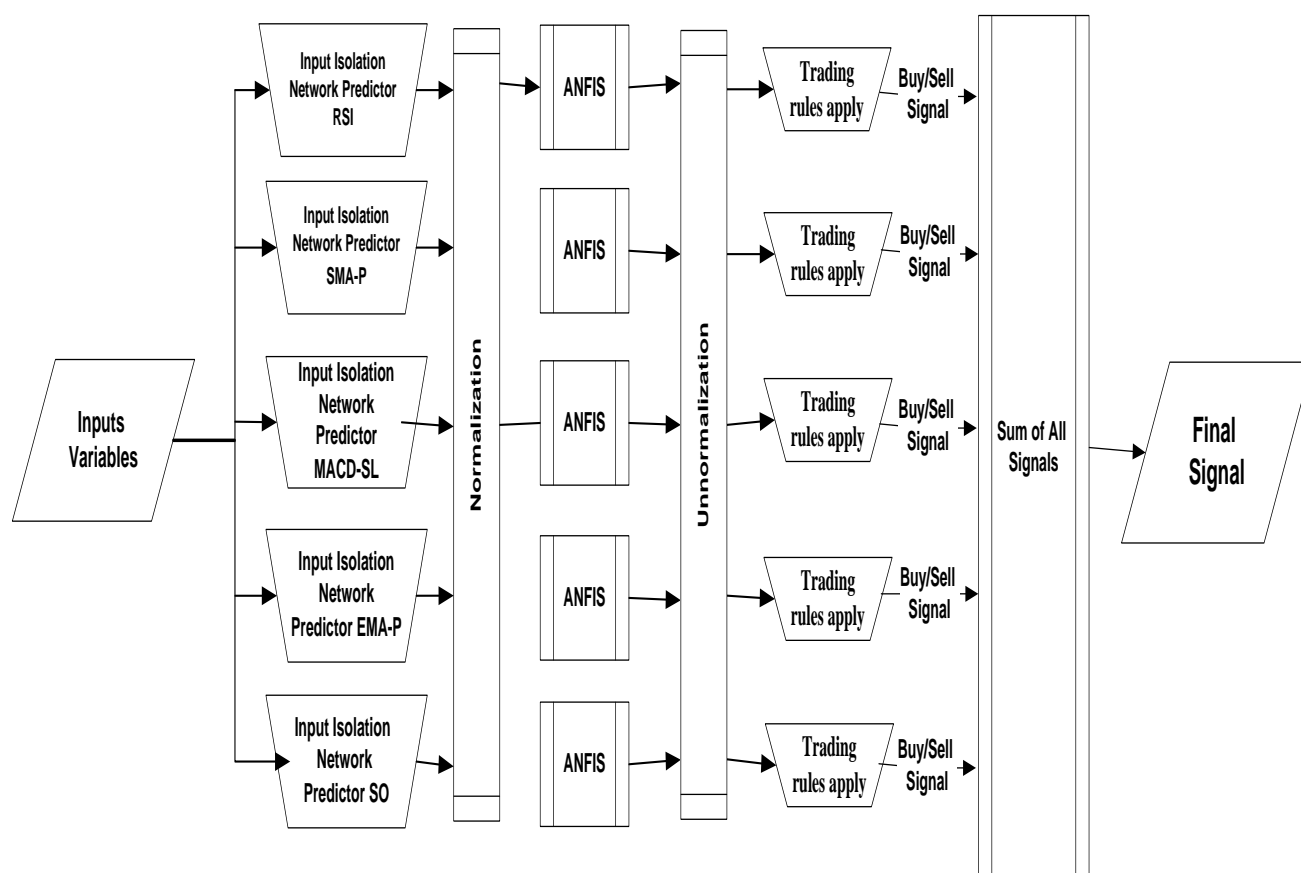

Figure 2. Conceptual Model

**Conceptual Model**

Figure 2 shows this study's conceptual model. As see in this figure, proposed model 14 past days data receive and predicts 14 next day RSI, SMA-P, MACD-SL, EMA-P, SO. Then, net outputs with transactions rules are changed to buy/sell signals. In the next step, the final signal is created by sum of generated signals. Thus, buy/sell is proposed during next 14 days. This model retrieved from Tan et al (2008) model. Tan et al (2008) used RSPOP and predict of RSI and EMA 5 next days for transactions timing. However, in this research have used ANFIS

network and predicting of RSI, SMA-P, MACD-SL, EMA-P, SO 14 next days to transactions timing.

### Research Methodology

This research is a descriptive study. In general, in this study have used the 20 independent variables that have been divided into four groups:

**Economic variables:** Exchange Rate (U.S. \$), World Prices per Barrel, Gold Price per Ounce.

**Price variables:** Closing Price, Lowest Price, Highest Price.

**Technical Analysis variables:** Relative Strength Index (RSI), Stochastic Oscillator (SO), Moving Average Convergence/Divergence (MACD), Sample Moving Average (SMA), Exponential Moving Average (EMA).

**Fundamental variables:** Total Index, P/E, Earning per share (EPS), Financial Efficient, Return on Assets, Return on Equity, Net Profit Margin, Asset Turnover, Payment (Obligation) Turnover, current ratio, quick ratio.

Present research needed data collected by library and Documentary method. This study population is the companies listed in Tehran Stock Exchange, which have the following conditions:

- Their data are available at specified time.
- Have been traded for over 60% of trading days.
- Are member of TSE at specified period.
- Are of different industries.
- Their stocks market value in compare to other companies in its group is high.
- The liquidity rank is highly.
- Are manufacturing companies.

Given that one of the selection criteria is liquidity high level, the manufacturing firms have been selected are in 50 active companies' quarterly reports in TSE during the period 1388 to end 1391. Then, in every industry, the firms that there was in Most reports and stock market value is more (17 companies), have been selected to study research subject. First, raw data that contains three variables, close price, lowest price and highest stock price during the period 1388 to 1391 as daily were collected from official TSE site. Then, RSI, MACD, SMA, SO, EMA and SL were calculated in Excel Software using these. In the next step, other variables were collected from relevant sources. Input variables of networks for each stock were identified using stepwise regression. These inputs were used in Matlab software by interface Anfisedit for training and testing the network. So that, five ANFIS networks were designed for predicting 14 next day's RSI, -SL MACD, SMA-P, SO and EMA-P. In the current study, 80 percent of data have used for training and 20 percent of data for testing. The numbers of membership functions on each network are selected using try and error. Rule number is also are considered equal to the number of membership functions. Five Networks has designed for each stock. Ultimately, 85 networks were designed for entire sample. After network training, designed network were examined with test data. To evaluate network performance has used of tow benchmark; Mean Square Error (MSE) and Root Mean Square Error (RMSE). These benchmarks calculated as below;

$$MSE = \frac{\sum (Y - Y_i)^2}{N}$$

$$RMSE = \sqrt{\frac{\sum (Y - Y_i)^2}{N}}$$

Then, predicated values are converted to signals by below trading rule:

- If "RSI" is greater than 70, send buy signal (by value=1) and if "RSI" is less than 30, send sell signal (by value=-1).
- If "MACD-SL" is positive, send buy signal (by value=1) and if "MACD-SL" is negative, send sell signal (by value=-1).
- If "SMA-P" is positive, send buy signal (by value=1) and if "SMA-P" is negative, send sell signal (by value=-1).
- If "SO" is less than 20, send buy signal (by value=1) and if "SO" is greater than 80, send sell signal (by value=-1).
- If "EMA-P" is positive, send buy signal (by value=1) and if "EMA-P" is negative, send sell signal (by value=-1).

So, proposed signal created by sum of 5 above signal. The next step should be to evaluate transactions return of the proposed method. Therefore, a hypothetical transaction is simulated using trading strategy.

- Buy stock in the first buy signal that its "RSI" value is greater than buy signals set and wait until the first sell signal that its "RSI" value is less than sell signals set. So, sell stock at that day. This process continues until last day. If at last day has stock, sell it and remove from market. Otherwise, remove from market no any action.

- Buy stock in the first buy signal that its "SMA-P" value is greater than buy signals set and wait until the first sell signal that its "SMA-P" value is less than sell signals set. So, sell stock at that day. This process continues until last day. If at last day has stock, sell it and remove from market. Otherwise, remove from market no any action.

Table 2

An example of decision based on SMA-P

value" "SMA-P	Predicated signal	Final decision	
-0.35	0	hold	
-0.42	0	hold	
buy signals set	0.04	1	hold
	0.26	1	buy
	0.12	1	hold
	0.09	1	hold
sell signals set	-0.18	-1	hold
	-0.05	-1	hold
	-0.29	-1	sell
	-0.12	-1	hold
buy signals set	1.25	0	hold
	0.85	0	hold
	1.73	0	buy

- Buy stock in the first buy signal that its "MACD-SL" value is greater than buy signals set and wait until the first sell signal that its "MACD-SL" value is less than sell signals set.



So, sell stock at that day. This process continues until last day. If at last day has stock, sell it and remove from market. Otherwise, remove from market no any action.

- Buy stock in the first buy signal that its "EMA-P" value is greater than buy signals set and wait until the first sell signal that its "EMA-P" value is less than sell signals set. So, sell stock at that day. This process continues until last day. If at last day has stock, sell it and remove from market. Otherwise, remove from market no any action.
- Buy stock in the first buy signal that its "SO" value is less than buy signals set and wait until the first sell signal that its "SO" value is greater than sell signals set. So, sell stock at that day. This process continues until last day. If at last day has stock, sell it and remove from market. Otherwise, remove from market no any action.
- Buy stock in the first buy signal that its final signal value is greater than buy signals set and wait until the first sell signal that its final signal value is less than sell signals set. So, sell stock at that day. This process continues until last day. If at last day has stock, sell it and remove from market. Otherwise, remove from market no any action.

### Results

Chart 1 shows designed network MSE of test data.

The observed error values of networks to test data base on MSE are between  $4 \times 10^{-4}$  and 0.1591. Network predicted SO for KCHAD has lowest MSE. Overall, the mean and standard deviation of all samples MSE is 0.034 and 0.031. Chart 2 shows RMSE values for networks designed for test data.

The observed error values of networks to test data base on RMSE are between 0.0215 and 0.3988. Overall, the mean and standard deviation of all samples RMSE is 0.071 and 0.085. In this study, predicated accuracy percent have calculated of  $1 - \text{MSE}$ . Chart 3 shows predicated accuracy percent of all created networks to test data. As it is clear from this Chart, all networks have predicated accuracy percent more than 50%.

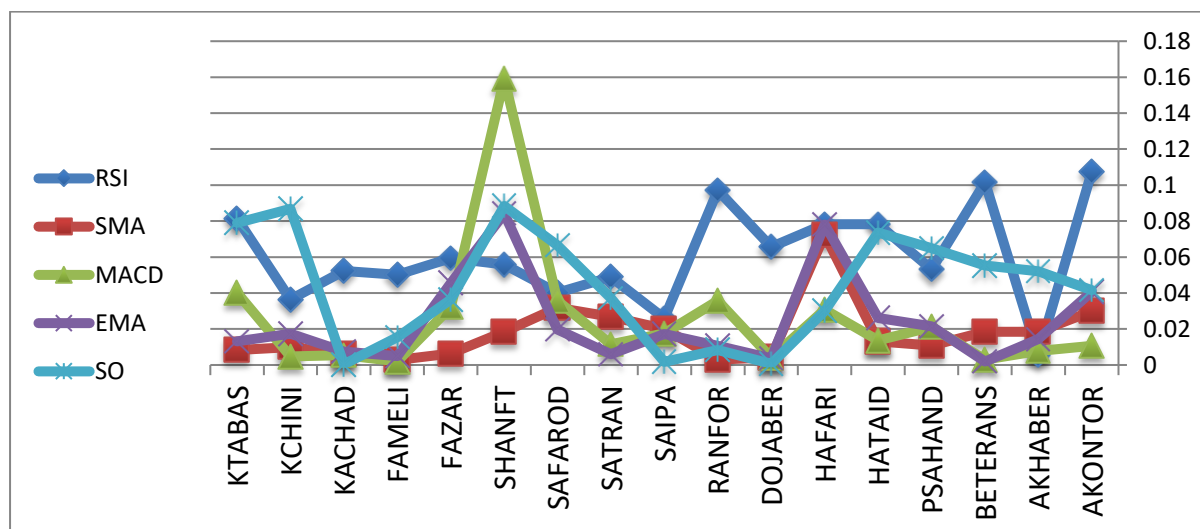

Chart 1. MSE of test data

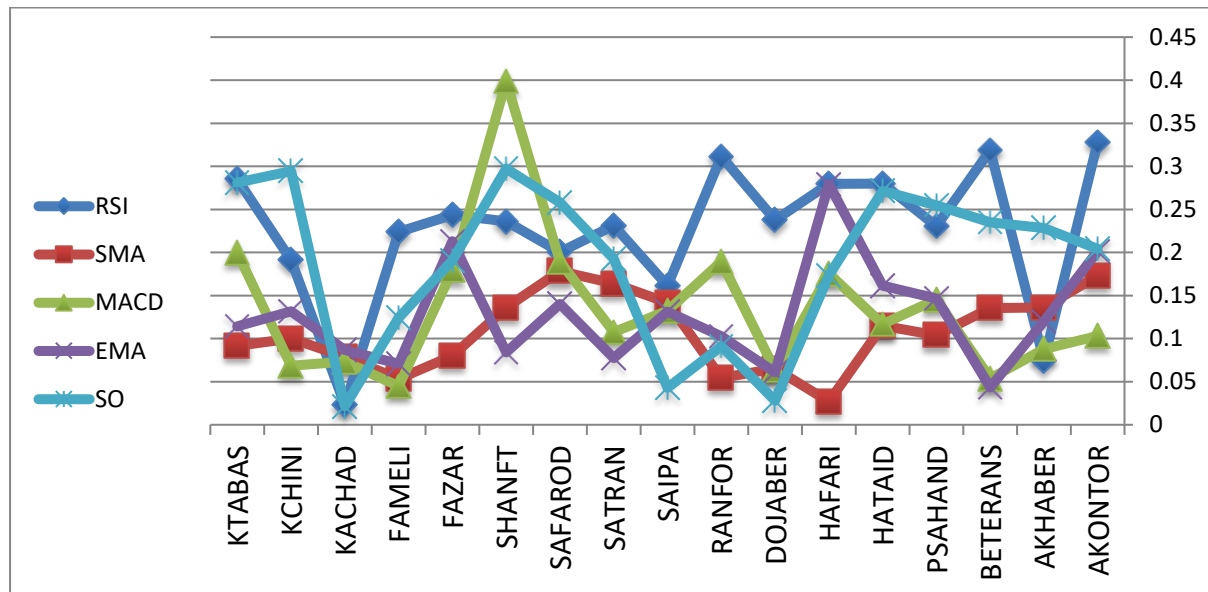

Chart 2. RMSE of test data

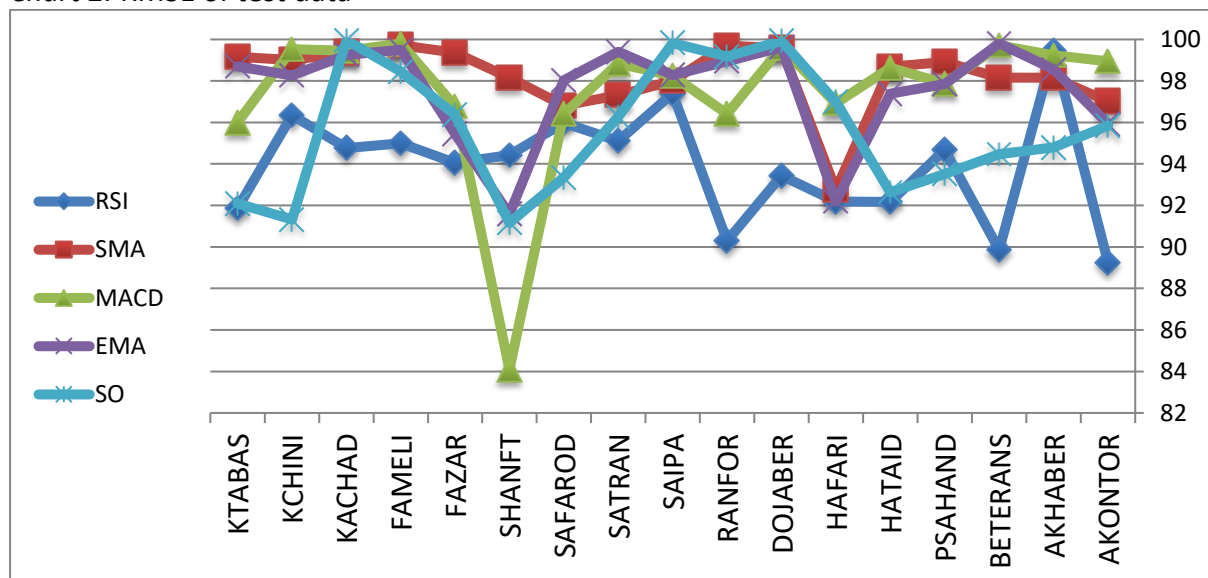

Chart 3. Percentage of forecasting accuracy test data

Percentage of forecasting accuracy test data values are between 84.09 % and 99.96% which is represents high efficiently of fuzzy neural network in technical analysis indicator predicting. Average percentage of correct predictions for all channels is 96.55% and its standard deviation is 3/14. Thus, first hypothesis is confirmed.

After simulating the trading by proposed transaction strategy were calculated total number of transactions and average daily returns generated by seven signals (RSI, MACD-SL, SMA-P, EMA-P, SO, buy/hold, the final signal model). These calculations were done on two cases (with considering transaction costs and without transaction costs). In this study, 0.0105 of stock value when purchasing will be add to stock value and 0.0055 of stock value when selling will be deducted from stock value. In other words, transaction costs, when you buy 1.05% of stock value and it is considered 0.55% of stock value, when you sell it. Based on research findings, the average daily returns of AKONTOR, FAZAR, HAFARI, KCHAD, KTABAS, SAFAROD, SHANAFT have highest value based on EMA-P signal. However, highest average daily returns in DOJABER, FAMELI, RANFOR, SAIPA is owned SMA-P. sum signals method in

the case of after deduction transaction costs has best performance only in HATAID and in the case of before deduction transaction costs in HATAID, KCHINI, AKHABER. Average daily returns trades based on SO signals in SATRAN, PSAHAND and BETERANS is higher than other methods. Table 3 shows descriptive results of daily return in two cases. As it is noticeable, in both cases, the average daily returns of the trading methodology based on SMA-P signal is higher than other methods. Also, The Average daily returns of proposed method (sum of technical analysis indicators signal) in both case are higher than buy/hold method. As you see at table 3, The Average daily returns of proposed method in after deduction transaction costs case is negative. It is seemed that large number of transactions in this method with increasing transaction costs is due to reduce daily returns.

Table 3

*Results of daily returns in different methods*

Method	Average hold period	Average number of transactions	before deduction transaction costs		after deduction transaction costs	
			Average of return	Standard deviation of returns	Average of return	Standard deviation of returns
RSI	50.88	1.47	-0.5824	0.4765	-0.6209	0.4975
MACD-SL	13.23	7.23	-0.5697	0.3756	-0.5852	0.5371
SMA-P	12.17	9.70	0.3672	0.3630	0.3231	0.4437
EMA-P	19.70	8.52	0.3352	0.3425	0.2418	0.344
SO	43	5.17	0.0624	0.5407	-0.0101	0.5305
Buy/Hold	271	1	-1.4584	5.4757	-1.4881	5.7209
Proposed signal	10.05	9.76	0.0090	0.2482	-0.1530	0.2056

### Conclusions and Recommendations

Results showed that all created networks have high prediction accuracy. Moreover, ANFIS has unique features of rapid convergence, high precision and strong function approximation ability. So, it is suitable to predict stock price trends. In other words, the results of this research indicate that neural networks have the ability to predict short-term stock price trends in TSE. It seems that compare of performance of fuzzy neural network each companies with another company in same industry to bring valuable results. Among the most important factors that affect stock prices and consequently on technical analysis indicators can be mention on other macro-economic variables such as inflation, GDP, foreign exchange reserves, fiscal and monetary policy, credit rates and political factors such as war, change the structure of government, world political systems situation and other variables including the stock Exchange structure and the its rules and regulations, the size and structure of corporate finance, firm dividend policy, level of income, trust amount of people to investors. Hence, is recommended the use of expert system to build the knowledge base in these fields and combined it with fuzzy neural network. Given the positive returns SMA, EMA, SO and proposed method It's can be results that using these indices of technical analysis can predict stock price trends of Iran stock market. In addition, SMA method has highest validity to predict stock price Trends. Thus, TSE has potential for applying of various indicators of technical analysis. Stock market and stock prices is affected by multiple factors, economic,

social, cultural and political. In this study, we tried to be due to economic factors. Investigation and Research on Genetic Algorithm and Fuzzy Delphi method is proposed in this way.

## References

- Boyacioglu, M. A., & Avci, D. (2010), An Adaptive Network- Based fuzzy Inference System (ANFIS) for the prediction of stock market returns: the case of the Istanbul Stock Exchange. *Expert Systems with Applications*, 37, pp. 7908-7912.
- Chang, P. C., Fan, C. Y., & Liu, C. H. (2009). Integrating a Piecewise Linear Representation Method and a Neural Network Model for Stock Trading Points Prediction, *IEEE Transactions On Systems, Man, And Cybernetics Part C: Applications And Reviews*, 39(1), 80-92.
- Chang, P. C., Liu, C. H., Lin, J. L., & Fan, C. Y., & Ng, C. S. P. (2009). A Neural network with a Case Based Dynamic Window for Stock trading Prediction, *Expert Systems with Applications*, 36, 6889-6898.
- Emami, A. A., Razmi, J., & July, F. (2007). Evaluate and compare the predictive rules of technical analysis in the Tehran Stock Exchange. *Fifth International Conference on Industrial Engineering*. 11 - 12 July. Iran University of Science & Technology.
- Shams, F. M., & Asghari, D. B. (2009). Tehran Stock Exchange index prediction using neural networks. *Beyond Management*, 3(9), pp. 212-191.
- Keng Ang, K., & Quek, C. H. (2006). Stock trading using RSPOP: a novel rough set-based Neuron-Fuzzy Approach, *IEEE Transaction on Neural Networks*, 1, 1-15.
- Kordos, M., & Cwiok, A. (2011). A new approach to Neural Network based stock trading strategy, *Proceedings of the 12th international conference on intelligent data engineering & automated learning*, Norwich, UK, September 7-9, PP. 429-436.
- Kuo, J., Chen, C., & Hwang, Y. C. (2001). An intelligent stock trading decision support system through integration of Genetic Algorithm based Fuzzy Neural Network and Artificial Network. *Fuzzy Sets and System*, 118, 21-45.
- Martinez, L. C., Hora, D. N., Palotti, J. R. D. M., Meria, J. W., & Pappa, G. L. (2009). *From an Artificial Neural Network to a stock market day- trading system: A case study on the BM&F BOVESPA*, International Joint Conference on Neural Networks.
- Mohammadi, S. H. (2004). Technical analysis on the Tehran Stock Exchange. *Financial Research*, 17, pp.129-97.
- Cheshmi, N. S. A., & Zadeh, H. A. (2011). Evaluate the effectiveness of technical analysis indicators MA in predicting stock prices. *Journal of Financial Security Analysis*, 10, pp.106-83.
- Sarfaraz, L., & Afsar, A. (2005). Investigating factors affecting the price of gold and predictive modeling based on fuzzy neural networks. *Journal of Economic Studies*, 16, pp. 165-150.
- Setayesh, M. A., Shayadeh, T. S. T., Mousa, P. A. A., & Abozari, L. A. (2009). Feasibility of using technical analysis indicators in predicting stock prices in the Tehran Stock Exchange. *Insight Journal*, 16 (42), pp. 175-155.
- Tan, A., Quek, C., & Yow, K. C. (2008), Maximizing winning trades using a Novel RSPOP Fuzzy Neural Network intelligent stock trading system, *Appl Intel*, 29, 116-128.
- Tehrani, R., & Abbasian, V. (2008). Application of Artificial Neural Networks in timing stock trading with technical analysis approach. *Economic Research*, 8(1), pp. 177-151.
- Thawornwong, S., Enke, D., & Dagli, C. (2003). Neural Networks as a decision maker for stock trading: a technical analysis approach, *International Journal of Smart Engineering System Design*, 5(4), 313-325.