

# **Attitudes and Behavior in Everyday Finance among Investors of the Securities Exchange**

**Mashala Valikhani**

Assistant Professor, Management Department, Islamic Azad University Dehaghan Branches,  
Iran

**Farzane Bijani<sup>1</sup>**

M.A. Public Administration, Management Department, Islamic Azad University Dehaghan  
Branches, Iran

DOI: 10.6007/IJARBSS/v4-i3/730 URL: <http://dx.doi.org/10.6007/IJARBSS/v4-i3/730>

## **Abstract**

We aimed to "evaluate the attitude and behavior finance daily among investors of the Stock Exchange is. This descriptive - survey research branch of the field is. Data were collected using a questionnaire with the help of statistical software SPSS and LISREL statistical test such as the Kolmogorov - Smirnov test, single-sample t test, ANOVA, Friedman test has been analyzed. The study sample consisted of stock investors are that over 700 people, and a sample of 252 individuals was estimated using Cochran's formula. The results indicate that anxiety and socio-demographic characteristics, financial interests, style of decision making, saving and saving, spending and attitudes tend to daily financial relationship exists.

Keywords: financial behavior - Investors - Social Issues

## **Introduction:**

Perhaps no subject in the financial literature is controversial than the question of whether investors in the stock price, reasonable act or not? One of the main assumptions of the efficient market theory and the capital asset pricing model Capital, a rational investor is rational. In the area of investment and dealing with money, so that we always think we do not act reasonably and exactly why the particular context of the research is where sometimes strange behavior of people in these areas are examined. Investors in the capital market (stock) in order to gain efficiency and profits must choose between investment options and decide to take action and commit during the decision-making errors be, Although the error is part of the learning process, but some of these errors and how they affect the structure of the human mind and cause wrong decisions and the reality is bias (RAMEZANI, 1387).

The behavioral finance literature, this kind of errors, perceptual errors can be attributed to the financial behavior of financial management is a multidisciplinary field of vision The utilization of

---

<sup>1</sup> . Corresponding author

other knowledge, particularly psychology, sociology, behavioral economics, experimental economics, social psychology and fundamental theories, such as chaos theory, order and chaos ... Is trying to identify more and better address market factors (ASGHARNEJAD, 1388). Not everyone is willing to live with clear objectives and decisions that are nice, peaceful and successful to provide for themselves. One of the most important goals in life, financial ability, and the judgment in this regard is the decision to invest. Do you want to make decisions for investment right now? Protect your money? To achieve your financial goals in life, investments, profits and increase your income. Goal is to identify an individual who is participating in the securities market. He has to earn profits and gain more interest in the market descends the steps. When in fact, individual investors hoping to get the next value from the current value to be ignored. If the factors encouraging the investment are not there, people typically prefer current consumption to future consumption (JAFARI, 1385). Investor buys a stock sheet investment has been made, but buy a house to live is not an investment. So an investor should expect to get from your current investment returns is positive and benefit from the wealth of opportunities in the future he would be encouraging if you have the impression that the market will bear for a time they can invest in stocks with low betas. In other words, knowing the betas of securities with respect to risk and return policies are able to adjust their portfolios to pay The bull market in stocks with a beta greater than one and a bear market in stocks with a beta less than one financial on their investment (Anvari A. Rostami, 1383). The explanation was provided about financial theory, goes without saying that the determining factor in whether or not these theories impact their investment. Milton Friedman believes that the only person who can truly persuade you is yourself and that you have the opportunity to debate in the minds of your own. In this study, researchers sought to examine attitudes and behavior in everyday finance among investors of the stock is, the main research question is therefore whether the attitude of the financial affairs of daily behavior among individual investors exchange relationship there?

#### - Behavioral Finance and Investment Financial Systems

Behavioral Finance: Financial today's most vital research programs at the head of the efficient markets hypothesis is rejected, the theory of economic behavior is the result of collaboration between financial sciences and social sciences and is causing the deeper our knowledge is of the financial markets. In literature of West, the nature of man as a rational creature which is under clear decision is defined. The complete inventory, which is often referred to as economic man always successful in optimizing the desired benefits and all the information on the choices and decisions affect, collects, and the ideal position that is certainly not found in the real world, many investors creates. But Herbert Simon - leading financial behavior - economic man being unrealistic in economic theories can be detected. Asttiman mortality in an article titled: review of asset allocation using behavioral challenges traditional theories of finance stated that individuals are rational while the financial behavior of normal people would assume, that an investor may decide that it is not economically justified. Financial behavior, as a theory of financial topics and issues with the help of theories of cognitive psychology explains. The modern financial theories such as the "Efficient Market Theory" are not only predictions but also at the micro level of doubt about the views as expected maximization and rational expectations are questionable. (Ansari and Karimi, 1387).

The theories of both micro and macro financial behaviors influence:

1. Microfinance behavior (BFMI): behavior or biases Investors and their rational economic actors in classical economic theory, introduced back.
2. Macro-economic behavior (BFMA): Identify and describe abnormalities in efficient markets theory to behavioral patterns, probably be able to explain it. Overconfidence causes of human knowledge and skills than what it is, is less than the risk estimate.

Now we face two fundamental questions: first, whether or not we are suffering from this psychological bias?

Second, the effect of this bias, what is the financial and investment decisions?

The answer to the first question is very difficult. All humans are commonly affected by such bias. For example, if you ask people, "You are driving in comparison with others is better than average or worse?" Most people will respond that "certainly better". However, if the answer to this question should be unbiased, half of them are better than average and the other half worse. What gave you the right answer to this question? If you're handling it better than others. There are many tests to test the behavioral biases. The remarkable thing is that everything in the domain of individual knowledge and skills, and confidence in one's own knowledge will increase.

Just why some economists that the economic analysis is to be too far from the reality of ordinary people. They speak with confidence from our mistakes and do not doubt his words. Important characteristics of this behavioral bias is the reason why it is said that overconfidence is learned and the people there themselves. Another point about bias is that men are more likely than women to have excessive trust in their own newly single men than married men there is greater confidence

This may be due to the presence of a woman with married men. (Biais & et al, 2005)

The effect of overconfidence on investors is that most people who trade. High transaction itself is not bad, and the ability to analyze transactional costs covers not a problem. Odean Barber During their studies further concluded that the transaction would result in lower annual returns. This is because the transaction costs of buying and maintaining a policy that is less than the benefit to be derived swing. Note that this is not the average of the different groups of investors are individual investors. Another effect of overconfidence is estimated at less risk. Here is the chances that a variety of research areas cleave the portfolio are those who had more self-confidence, risk more than others and thus have a lower risk-adjusted return.

These brief statements of the behavioral biases that affect people were talking. This bias is low, and even many of these biases have led to contradictory behavior of an individual. The fundamental problem is that the bias and limit the amount of investment consulting firms to determine their risk Based on your advice and do that or different baskets based on varying degrees of investment risk form and provider customers. Thus attracting capital easier and more efficient it will be. (Barber, 2003).

-Invest in stock

Despite the activities of the stock exchange in 1347 and died about 35 years, the number of people engaged in the field of trade is small And awareness of such trade is not desirable. Most investors are familiar enough with the conventional methods of investment and its implications. Investing in the stock market and there is no simple means of identifying the

numerous companies and their selection will be difficult. But in the age of information without knowing the methods of selecting stocks entering the field of investment and trade will bring disappointment. More on this topic in the early stages of the basic concepts of investment and activity in the market get to know. I must say that learning new ways to invest and trade models, more fun securities' playing and what you will learn with interest test. (noorbakhash,1388).

-Principles of investing in the stock

Stock market like any other market in the principles and conditions, particularly with regard to the basic principles and practice, accepting the lowest possible risk to invest can be made in. Investment "extra finance" First and foremost, the main emphasis always advises officials and activists with experience in the market. Due to market fluctuations in Via Since this sequence is the same situation, investors can usually safely, and sectional crises that have put up with stock investing its surplus in the online market and also enjoy basic essentials of life (Housing, automotive, housekeeping, etc.) have injected additional capital into the market. Of being indebted to others in order to avoid investing in the stock market to take the initiative and do not lose your memory expansion (Kannan,2004).

● Portfolio

Avoid buying "one stock" portfolio formation, the second important principle to reduce the risks of investing in the stock market. Since the company's stock price fluctuations are different trends, its available capital to buy stakes in several companies in various industries to inject risk capital is reduced. Few, if any, of capital, financial intermediation companies (having a diverse portfolio) investment because the risks of such firms are lower than other companies.

- Long-term perspective

The third principle of exchange is long-term investment view. Past experience and various stock indices also show up in any period of three years, shareholders have suffered losses, and depreciation of capital. So what is seen as longer-term investors than minimal risk coefficient?

- Uncertainty

Uncertainty in the market, another principle that shareholders must be considered in any circumstances. Sometimes "has been seen that people only spend the returns on a stock exchange or market indexes turned.

While the SEC to "Hall of glass" is known to fail and leave the good shove picks should always bear in mind that the status (positive or negative) of a stock exchange cannot be extended to future times. In other words, the market principle "the only constant is change" is a perfect example.

- Analysis

To obtain a reasonable return above the scholarship must be considered. In addition to the common practice analysis (fundamental, technical) conditions to achieve the highest return in the shortest possible time to prepare. Modern portfolio theory (MPT) to effectively help balance risk and return portfolio optimization offers.

- Fundamentals

Literally: the basic foundation and knowledge exchange trading is a kind of analysis that examines the fundamental and all-stock companies in the micro and macro level deals(Guthrie,2011).

1. To those who are using this method to analyze (fundamentalist) say. Investor in any market, including bonds, gold, currency, and housing and ... Always requires a comprehensive evaluation of investment opportunities and costs that come and go are. In fact, based on the analysis of existing data and predict the impact of events on the investment opportunities the way they are used by many analysts. In this approach, the analyst began his career with holism and other (international studies, national, regional, industry and company) is formed. Assess the costs and opportunities and risks along with the reasons and compared with other available data to predict future events, the foundation for such analysis(Baltagi, 2005).

- **Technical Analysis**

Technical analysis is one of the leading methods in the study of the company's stock price. As the formal parameters (supply and demand, the turnover number of buyers historical prices) is based. In other words, technical analysis uses past data to predict future events. Analysts who are using this method to check stock or technician (Chartist) say. In this type of analysis, using various charts and indicators is the basis for a substantial share of the Chartist information no matter. In some cases, the Chartist no idea what products are purchased from the company that produces it in stock(Amyraslany,1384)..

3 This principle forms the basis of:

- A) Everything is reflected in the share price.

Chartist agree that all information and instead take a share of their impact on the share price and the need to track

No company events and the evolution of the company's share price.

- B) price trend will resist change

If a company's stock price to change (increase or decrease) the change is positive or negative one to zero. In other words, price range, negative to positive will move, but it tends to zero and balance.. Accordingly, the share price never happen in a moment, and suddenly the balance unlikely to occur during the period This event takes place during a period when the market's behavior during this period shows us how much time is left until the end. For example, when a company's stock has a positive trend in the way we reach the point from which the percentage increase in prices will decrease relative to the previous day or conversely, a negative trend accelerated when deflation was quiet compared to the last few days that we are close to equilibrium(T abarsa,1379).

- C) Date (process) is repeated

If we accept that from a psychological point of view, humans have a similar reaction in similar circumstances, could easily reflect the principles of the psychology of buying and selling them to contribute and a review of past events, we can easily predict the future(Camerer,2004).

-The role of behavioral finance for investors:

Investors can benefit from the use of "behavioral finance" special situations are widely enjoyed."Behavioral finance" is a relatively new concept for investors and investment advisers that may occasionally accept or have questionable validity. In addition, advisors may ask questions of the psychology of our customers to realize their desires, they are reluctant.

When the market is developed behavioral finance, investors will see the benefits and understand how they are expected to affect investor psychological consequences of investments, provide new insights. Expected result of proper communication to create with "behavioral finance" for advisors and portfolio managers that a consultant can be tailored to each investor's goals and desires. (Barberis, 2007)

Assumptions:

1. Between anxiety and socio-demographic characteristics, attitudes are related Financial Daily.
2. Financial interests and socio-demographic characteristics, attitudes, daily financial relationship exists.
3. Style of decision-making and socio-demographic characteristics, attitudes, daily financial relationship exists
4. Between saving and savings to avoid financial risk attitudes Vjmyty social features daily relationship exists
5. Willing to spend between socio-demographic characteristics and attitudes in daily financial relationship exists.

Research Methodology:

This study is based on the nature and methods of descriptive - survey is the branch of athletics.

The population"

The study sample consisted of stock investors are that over 700 people, and a sample of 252 individuals was estimated using Cochran's formula.

Data collection

The method of collecting data related assumptions, and tools used by the census questionnaires, interviews, library, internet, reports Documents are reviewed.

Variables

The variables in this study include:

The independent variable

Financial outlook

Anxiety and demographic

Financial interests

Style of decision making

Savings and Savings

Dependent variable

Willing to spend

Reliability and Validity:

Researcher made questionnaire used in this study to measure attitudes and behavior among investors in the Stock Exchange's daily finances of Isfahan. In this study, the validity of validity is used. In accordance with these principles in order to get the validity of professors and experts were asked to study the question of reform in the questionnaire apply Collecting opinions and conclusions and apply them again to give questionnaires given after performing again, ultimately a question of Professors and experts were got approved. And for determining the reliability of the questionnaire, the Cranach's Alpha was used.

$$r_a = \left( \frac{k}{k-1} \right) \left( 1 - \frac{\sum \delta_j^2}{\delta^2} \right)$$

Alpha value for each factor was calculated from the output of statistical software SPSS. Cronbach's alpha coefficient in this study indicates acceptable consistency of asking questions and taking responsibility for same. Cronbach's alpha coefficient in this study was a pilot study with the 30 questionnaires distributed among investors took stock of, are described below.

Table reliability variables

schCronba'Alpha	variable/factor
.75	Investment
.79	Savings and Saving
.82	<b>financial interest</b>
.78	<b>risk and anxiety</b>
.75	Method investment cost
.86	<b>total</b>

Methods of data analysis:

Independent sample Kolmogorov - Smirnov test for normal distribution of study variables, analysis of variance to assess differences meaning of variables, the Friedman test to evaluate differences between variables meaning supporting conditions SEM study to evaluate the suitability of the questionnaire used. And then using single-sample t-test study, we investigated the effect of the variables. Both descriptive and inferential analysis of the data was examined.



First hypothesis: socio-demographic characteristics between anxiety and daily financial attitudes are related.

Table (4-8) one-sample t-test of the first hypothesis

P	degrees of freedom	t	average	first hypothesis
<b>.000</b>	<b>251</b>	<b>11/7</b>	<b>3/5</b>	anxiety and characteristics of ...

Table (4-8) was statistically significant t value against the hypothesis is confirmed. Thus, anxiety and social and demographic characteristics of the daily financial attitudes are related.

Second hypothesis: There is a relationship between financial interests and attitudes Financial Daily.

Table (4-9) one-sample t test of the second hypothesis

P	degrees of freedom	t	average	second hypothesis
<b>.000</b>	<b>251</b>	<b>9/4</b>	<b>3/4</b>	Financial interest

Table (4-9) was statistically significant t value against the hypothesis is confirmed. So there is a relationship between financial interests and attitudes Financial Daily.

Third hypothesis: the relationship between styles daily financial decisions and attitudes there.

Table (4-10) one-sample t test of the third hypothesis

P	degrees of freedom	t	average	third hypothesis
<b>.000</b>	<b>251</b>	<b>11/09</b>	<b>3/5</b>	Decision-making style



Table (4-10) was statistically significant t value against the assumption is confirmed. Therefore styles daily financial decisions and attitudes are related.

Fourth hypothesis: the economy and daily financial savings and attitudes are related.

Table (11-4) one-sample t test of the fourth hypothesis

P	degrees of freedom	T	average	fourth hypothesis
<b>.000</b>	<b>251</b>	<b>10/6</b>	<b>3/3</b>	<b>saving</b>

Table (4-11) t-values are statistically significant and opposite assumption are confirmed. So between saving and saving and daily financial attitudes are related.

Fifth hypothesis: the willingness to spend a day there are financial outlook.

Table (12-4) one-sample t test of the fifth hypothesis

P	degrees of freedom	T	average	fifth hypothesis
<b>.000</b>	<b>251</b>	<b>17/2</b>	<b>3/6</b>	<b>willing to spend</b>

Table (4-12) t-values are statistically significant and opposite assumption are confirmed. Thus the tendency to day financial expenditure and attitudes are related

Evaluation of models:

One of Lisrel output, independent agents will be analyzed, which is shown in Figure 1.

- 1) Anxiety and demographic

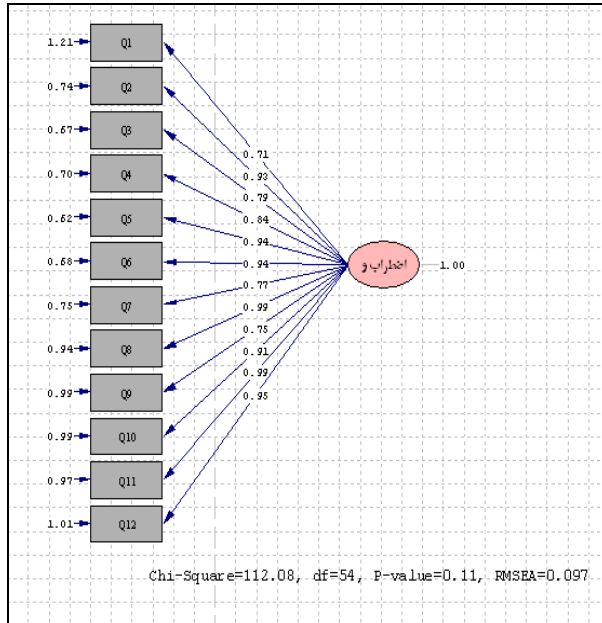

2)Tend to spend

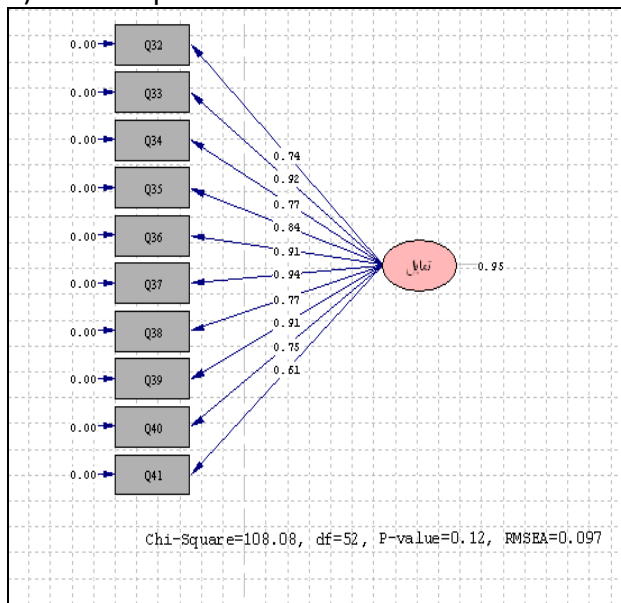

3)saving

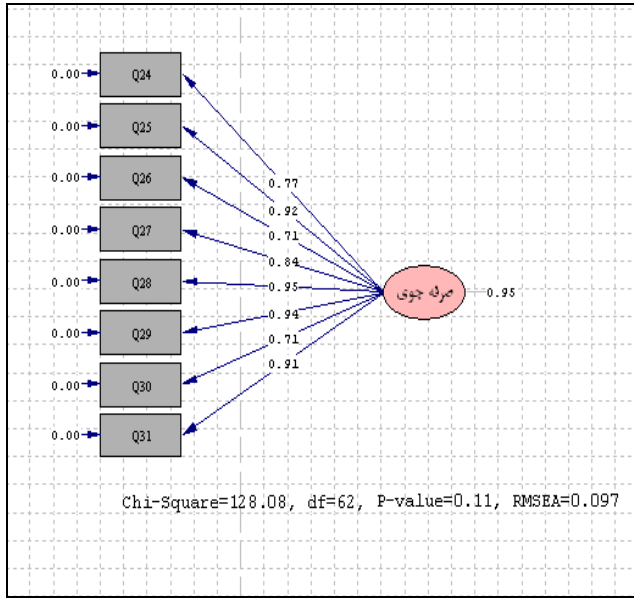

4) financial interest

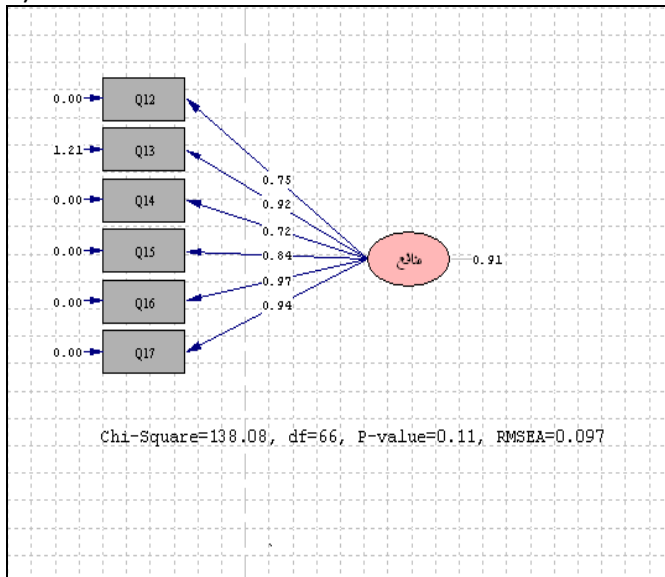

5) Decision making style

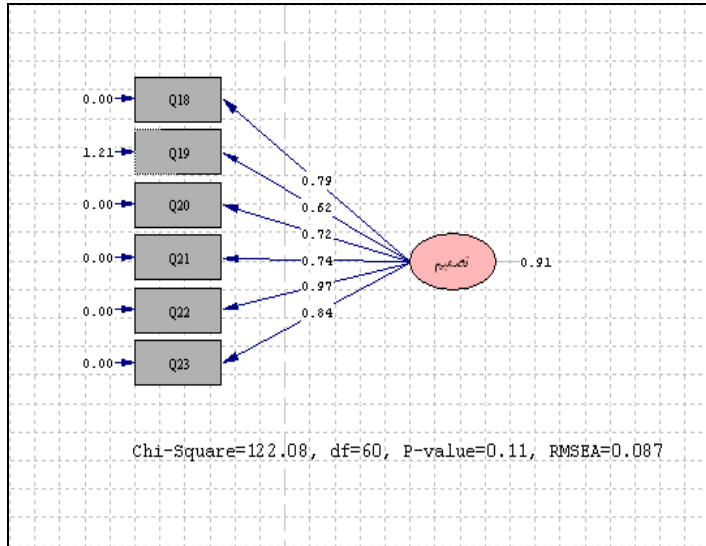

## 5.2 - Conclusion and recommendations

Due to recent developments in stock market, you need all the internal and external factors to be investigated if not elegant, fine-sighted, because our thoughts, ideas and mentalities are facing a wide variety of people who understand the mind is very important. School or behavioral finance perspective on the integration of psychology and finance there is suggests that psychology plays a role in financial decisions. Since the theories of cognitive errors and distortions affecting investment, thus affecting the financial options. Relationship between finance and other social sciences, which are known as the financial Psychology, Researchers have made a lot of studies on the behavior of investors in financial markets, react in different situations to take action. Regarding the causes of the rise of behavioral finance, a better understanding of the behavior of investors, to understand the decisions that are taken as asset management companies and banks relationship with customers can be noted. With the arrival of other sciences, including human sciences - as the most important factor in decisions, particularly investments - including psychiatry, psychology and sociology horizons and new perspectives are brought to the front finance And a new door to enter a new school of behavioral finance in order to progress in the field of finance as opposed to open. Levels and the emergence of behavioral finance integrated national standards and construction standards based on demonstrated financial issues explained what it is not always true. Behavioral finance has deviations, mistakes and lack of clear answers. In other words, the recognition of a new effect, but it did not heal or respond. As we were told, psychological factors, significant influence over the movements and actions of human beings, and this is a psychological problem that has distinguished them from each other, But sometimes it's less of a factor than external factors, researchers have been, While the understanding of behavioral processes and their implications for financial planners is extremely important and can equip them to develop strategies and allocate funds to help. For example, the inner dimension of the iceberg is submerged and only the tip of the peak and the (external factors) and the water level is visible from most parts of the iceberg (internal factors) is hidden below the water surface. However, given that the stock exchange is one of the pillars of economic growth and development, the organization will have to develop the national economy, Should be more understanding of psychological factors, and thus the inner mind to the outer behavior of people (investors,

futures) and the calculated scientifically discovered and led to improved diagnosis, attitudes, modes of behavior and investors, and the development of TSE will be achieved. According to behavioral finance new knowledge in the world and Iran on the one hand and the development of capital markets in order to attract more investors on the other, Behavioral finance research focused on understanding the particular needs of investors, investment and estimate their probable errors as a fundamental pillar of the market capitalization of the scientific and systematic manner, is two-fold importance. Research of this kind to be richer and applied this knowledge to help in this area. Investors in the capital market (stock) in order to gain efficiency and profitability of alternative investment choices must take action and decide if it's the same decision errors are committed, although the error is part of the learning process, but some of these are systematic errors that disproportionately affect the structure of the human mind and lead to wrong decisions and bias is the fact. In the hope that the authorities and relevant organizations impact on the securities markets by taking our delicacies all important factors influencing buyer behavior, considering the subtleties of all the important factors that affect the behavior of buyers, the power of the organization increases with its support national economic growth provide.

Suggestions:

1-- As noted, the stock market, the professional market than any other market recognition of self and psychological characteristics and personality of the investor is important, if the investor fails to analyze their strengths and weaknesses and know how to market properly recognize or respond to the market. Perhaps his lack sufficient knowledge of the search cost is high. One of the weaknesses of the venture capital market in training for this lack of attention to the psychological and sociological issues which the investor and the huge losses to the investor will be followed by. Therefore, the presence of masters in psychology and sociology classes stock held Garble Kendra capital investment markets will examine all aspects of Rated and anxious to harness the market to react properly reaction.

- 2) Individual investors hoping to gain value in the future, regardless of the current value are. If there are factors encouraging investment, people typically prefer current consumption to future consumption. So an investor should expect to get from your current investment returns is positive and benefit from the wealth of opportunities in the future he would be encouraging. Therefore, the government should have more control over the stock market to prevent any fraud and financial corruption Webster everyone is a good investment for the benefit of individuals, not the bed Speculative place
- 3) About four investors educated decisions you know according to the proposed models of consumer behavior, we found that the center of gravity models of consumer decision-making process is influenced by internal factors, external perceptions of self, consumer lifestyle and his experience and knowledge will lead to a purchase decision. These areas offer easy access investors aware of the different ways they are making can be fixed.
- 4) Investment commitment of money or capital to purchase investment there and the knowledge and insights are more important. High savings rate. It is proposed those financial institutions, instruments or other assets in order to return the beneficial interest in the form of interest, dividends or appreciation of the value of the items

(capital gains) is. Which is dependent on savings or reduce consumption? As noted, one of the weaknesses of the venture capital market in this training due to lack of investor psychological and sociological issues. So, with the cooperation of the capital markets and media attitudes about money in low-risk markets improve.

## References

1. Ansari and M. Karimi. In 1387. Financial criteria to evaluate management's performance evaluation on value creation for shareholders, with emphasis on economic criteria, *Accounting*, 200: 3-11.
- 2-AMIRI M ASGHARNEJAD. , 1388. INTELLECTUAL CAPITAL MEASUREMENT AND EVALUATION OF ITS RELATIONSHIP WITH FINANCIAL PERFORMANCE, *ACCOUNTING AND AUDITING REVIEWS*. 57: 101-116.
- 3-Amyraslany h. In 1384. The economic role of the audit in free markets and regulated markets, *Corporate Audit Management Standards*, Publication 59: 26
- 4-Anvari A. Rostami, H. saddle. In 1383. The correlation between economic value added, earnings before interest and taxes and cash flows of operating activities with the stock market value of listed companies in Tehran Stock Exchange, *Accounting and Audit Reviews*, 37: 3-21.
- 5-Baltagi, B., *Econometric Analysis of Panel Data*, John Wiley & Sons, third edition, 2005.
- 6-Barberis, N. (2007), "A survey of behavioral finance", in Constantinides, G.M., Harris, M. and Stulz, R. (Eds), *Handbook of the Economics of Finance*, Elsevier Science BV, Amsterdam, pp. 1051-121.
- 7-Biais, B., Hilton, D., Mazurier, K. and Pouget, S. (2005), "Judgemental overconfidence, self-monitoring, and trading performance in an experimental financial market", *Review of Economic Studies*, Vol. 72 No. 251, pp. 287-312.
- 8-Brennan, M.J. (2003), "The individual investor", *The Journal of Financial Research*, Vol. XVIII No. 1, pp. 59-74.
- 9-Camerer, C.F. and Loewenstein, G. (2004), "Behavioral economics past, present, future", in Camerer, C.F., Loewenstein, G. and Rabin, M. (Eds), *Advances in Behavioral Economics*, Russell Sage Foundation, New York, NY, pp. 3-51.
- 10-Guthrie, J., Petty, R. and Johanson, U. (2011), "Sunrise in knowledge economy : managing, measurement and Reporting", *Accounting, Auditing & Accountability Journal* , Vol. 14 No. 4, pp. 366 – 382.
- 11-JAFARI M., REZAEI LIGHT C, R. HASSANI. , 1385. REVISED MEASUREMENT MODEL OF INTELLECTUAL CAPITAL: A HOLISTIC APPROACH, *FOURTH INTERNATIONAL CONFERENCE ON MANAGEMENT, FACULTY OF MANAGEMENT AND ECONOMICS, SHARIF UNIVERSITY OF TECHNOLOGY*.
- 12-Kannan, G. and Aulbur, W, G, (2004), "Intellectual capital : measurement effectiveness", *Journal of Intellectual capital*, Vol. 5, No. 3, pp. 389-413.
- 13-noorbakhash Langroodi (1388). Evaluation criteria to assess the financial performance of the Tehran Stock Exchange. Pp. 1-11
- 14-RAMEZANI M. IN 1387. EXAMINE THE RELATIONSHIP BETWEEN EVA AND RETURN ON ASSETS AS MEASURES OF PERFORMANCE IN LISTED COMPANIES IN TEHRAN STOCK EXCHANGE, *STOCK EXCHANGE*, 74: 4-11

15-Tabarsa.1379. Review and explain the role of strategic requirements in the selection of evaluation governmental organizations, Proceedings of the martyr Rajai Festival executive performance evaluation, Tehran: Organization and Administration of the civil service.